

# Yamato

**YAMATO CORPORATION**

1775 S. Murray Blvd.  
Colorado Springs, CO 80916 USA  
Tel (719) 591-1500 Fax (719) 591-1045

**YAMATO TECH CORPORATION**

#112-19425 Langley By-Pass  
Surrey, B.C. V3S 6K1 Canada  
Tel (604) 533-2338 Fax (604) 533-0827

## Table of Contents

I.	Introduction	1
	A. Precautions	1
	B. Setup	2
	C. Display Panel and Operating Keys	3
	D. Power On, Zero Reset and Tare	4
II.	Operating Parameters	5
	A. Setting Parameters	5
	B. Storing Parameters	6
	C. Recalling and Verifying Parameters	7
III.	Operating Modes	9
	A. Combination Modes	9
	1. Any Quantity	9
	2. Set Quantity	10
	3. Priority Combination	11
	B. Sorting Mode	11
	C. Two Operator Mode	12
	D. Consecutive Number / Batching	13
IV.	Troubleshooting	14
	A. Checking the Scales	14
	B. Scale Suspension	15
	1. Suspending a Scale	15
	2. Identifying and Clearing Suspended Scales	16
	C. Error Messages	17
V.	Appendices	20
	A. Specifications	20
	B. Drawings	22

## I Introduction

This manual explains how to setup, store data in, operate and troubleshoot the TDW-204W scale. Section I lists important safety precautions, setup and basic scale operations. Section II describes how to store operational data into the TDW-204W memory registers. Section III illustrates the most popular operating modes of the TDW-204W. An additional mode, sorting, is available as an addendum to this manual. Section IV deals with troubleshooting procedures, and Section V contains appendices with specifications and drawings.

### I.A Precautions

1. Never apply unnecessary force to the weighing units.
2. Do not “shock” load or drop the scale.
3. Place the scale on a stable surface that supports all units of the scale uniformly.
4. Do not overload the individual scales. Do not sit or lean on the scale platforms.
5. Disconnect the power cord before fitting or removing any connectors.
6. Ensure the alignment key and receiving slot are properly aligned when fitting a connector. Push the connector all the way in, then securely tighten the captive ring.
7. Do not scrape or hit the membrane of the display panel or the back of the scale assembly with a brush or any hard, sharp material.
8. Never loosen the screws of the display panel or the scale platforms.
9. Do not place the scale in water.
10. Do not use paint thinner, benzene, sodium hypochlorite or other chemicals to clean the scale. To sterilize the scale platforms, remove them from the scale.
11. Disconnect the power cord when the scale is to be left unused for a week or longer.
12. Keep the power cord and connectors free from water and oil.
13. Never connect or disconnect the power cord with wet hands.

## I Introduction

### I.B Setup

1. Remove the protection brackets from the scale assemblies and the stop screws from the scale platforms.
2. Place the scale on a flat, level, sturdy surface. Avoid any location that exposes the scale to vibration and air currents.
3. Adjust the leveling legs on each scale unit to bring the bubble level indicator to center.
4. Match each of the connectors from the four scale units to the appropriate receptacle in the back of the control panel. Align the slot in the connector with the key in the receptacle and press the connector all the way into the receptacle. Securely tighten the captive ring.
5. Connect the power cord to an appropriate power supply receptacle. Do not use power lines that are connected to machines that demand high current. Voltage fluctuations in the line voltage may have an adverse affect on the scale's performance.
6. Ground the scale to ensure safety and to reduce electrostatic interference.
7. Adjust the angle of the control panel for easy viewing with the knobs on the side of the panel.
8. Do NOT place any object on a scale platform that weighs more than the scale's rated capacity.
9. The scale may be washed with water from a hose and a mild detergent. Do not use paint thinner, benzene, sodium hypochlorite or other chemicals. Avoid water jet spray into the underside of the scales.
10. Ensure there is nothing on any of the scale platforms prior to switching on or making a zero adjustment of the scale

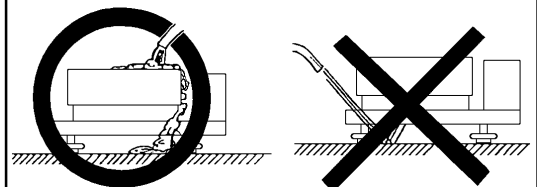
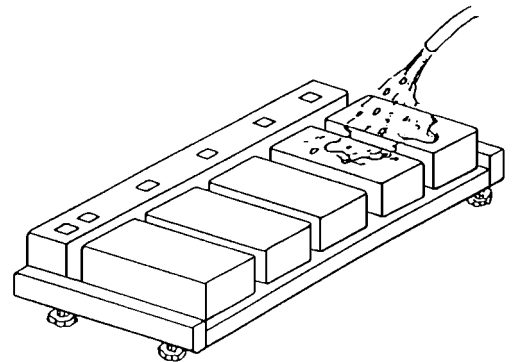
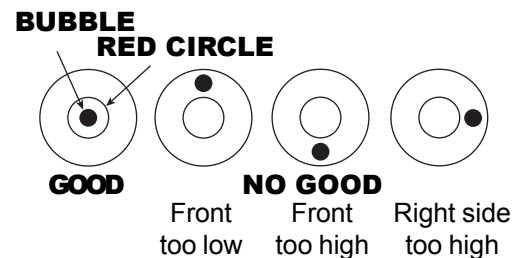
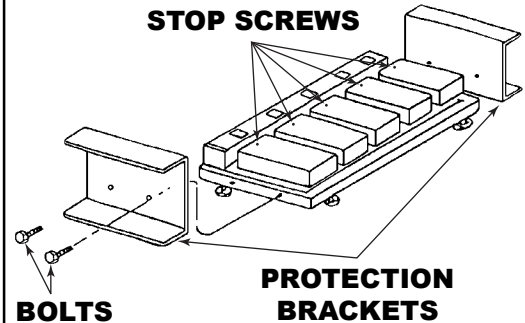

## I Introduction

### I.C Display Panel and Operating Keys

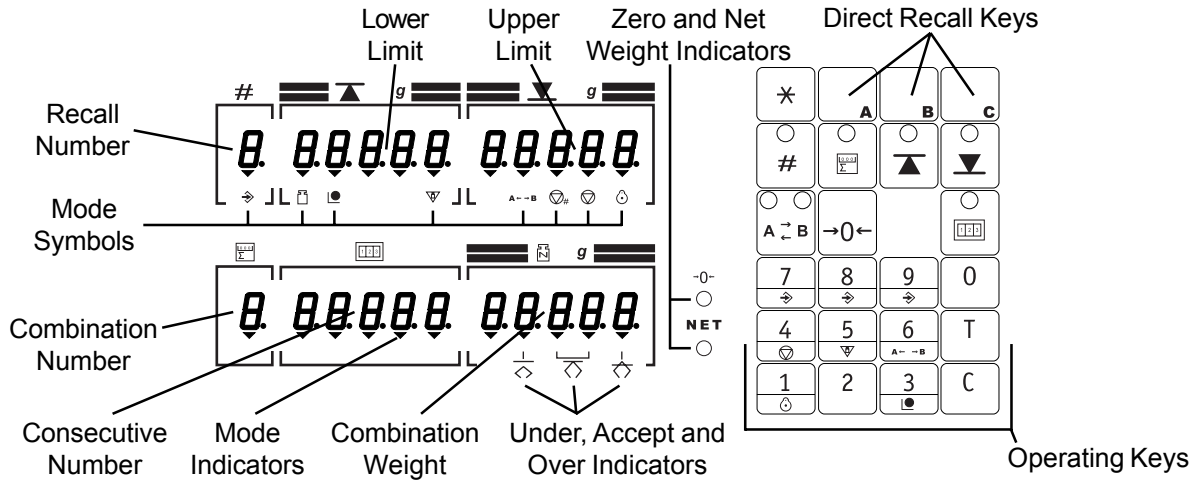

- |  |  |  |  |
|--|--|--|--|
|  | Returns to weighing mode after entering settings. Recalculates combination. Shift key to select a mode in combination with the numeric keys. |  | Numeric 1. Parameter storage register 1. Selects priority combination mode.                            |
|  | Direct parameter storage register A.   |  | Numeric 2. Parameter storage register 2.   |
|  | Direct parameter storage register B.   |  | Numeric 3. Parameter storage register 3. Selects sorting mode (see addendum.)                          |
|  | Direct parameter storage register C.   |  | Numeric 4. Parameter storage register 4. Selects scale suspension mode.                                |
|  | Shift key to select parameter storage registers 1 - 0 in combination with the numeric keys.  |  | Numeric 5. Parameter storage register 5. Selects scale check mode.                                     |
|  | Sets the number of items in a combination.   |  | Numeric 6. Parameter storage register 6. Selects two operator mode.                                    |
|  | Sets the lower weight limit.   |  | Numeric 7. Parameter storage register 7. Selects memory mode in combination with numeric keys 8 and 9. |
|  | Sets the upper weight limit.   |  | Numeric 8. Parameter storage register 8. Selects memory mode in combination with numeric keys 7 and 9. |
|  | Selects group A or B to be displayed during two operator mode.   |  | Numeric 9. Parameter storage register 9. Selects memory mode in combination with numeric keys 7 and 8. |
|  | Zeroes all scales simultaneously.  |  | Numeric 0. Parameter storage register 0.   |
|  | Sets the consecutive batch number.   |  | Tares all scales simultaneously.   |
|  |  |  | Clears current entry.  |

## I Introduction

### I.D Power On, Zero Reset and Tare

1. Turn the power switch on. All LCD segments and LED indicators will flash several times. Determine if any segments or indicators are not functioning.

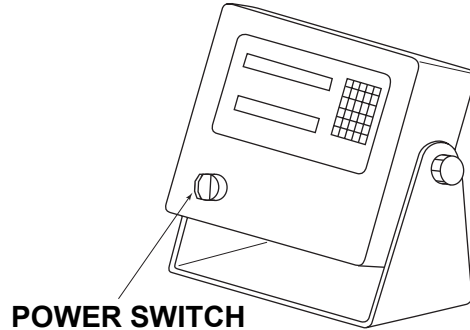

#### NOTE

A value must be entered into the lower limit and upper limit registers before the scale can be zeroed or tared. See section II.A for instructions to load these parameters.

2. The scale zero should be reset prior to operation. Zero reset can only be performed in weighing mode. With nothing on any of the scales press the  key. All twelve scales perform zero reset one at a time. When the resets are complete the buzzer will sound and the zero indicator lamp will light.

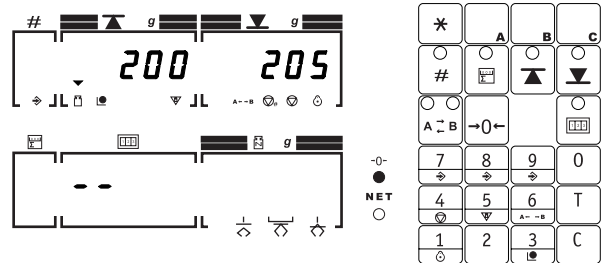

3. Place an empty container on each scale to be tared. Press the  key. All twelve scales tare one at a time. When taring is complete the buzzer will sound and the net indicator will light.

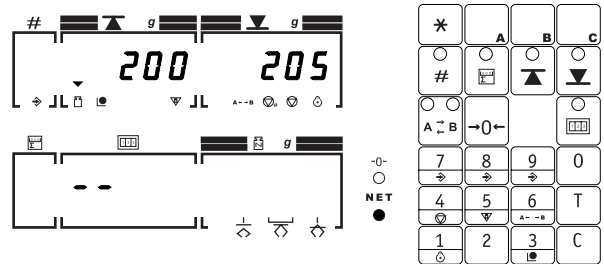

4. Pressing the  key will cycle between gross and net weight indication.



## II Operating Parameters

The operating parameters of the TDW-204W consist of the lower weight limit, the upper weight limit and the combination number. The TDW-204W has a total of thirteen memory registers in which a full set of these parameters may be stored. Three of the registers (A, B and C) offer direct storage and recall, while ten of the registers are accessed through a shift, , and numeric (0 - 9) key combination.

In two operator mode, separate parameters for both sides A and B can be stored in each of the thirteen registers. Choose the desired side before entering, editing, storing or recalling any parameters.

An intermittent buzzer will sound after setting the upper and lower limits if any of the following conditions occur:

- The lower limit is greater than the upper limit,
- Either limit is greater than the maximum combination weight of the scale, or
- Either limit is less than the minimum combination weight of the scale.

Press the  or  key to silence the alarm, then correct the entries.

### II.A Setting Parameters

1. To enter or change the lower limit, press the

 key and enter the lower limit.

Example: 200 g

Press  2 0 0

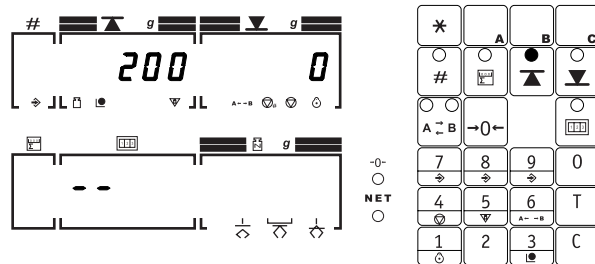

2. To enter or change the upper limit, press the



 and enter the upper limit.

Example: 205 g

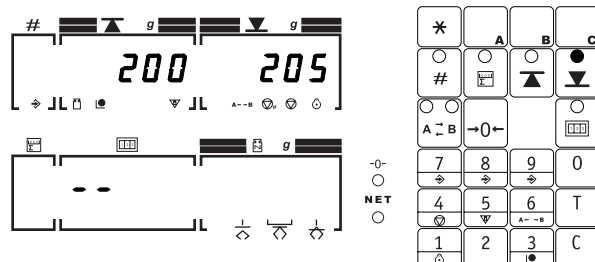
Press  2 0 5



3. To enter or change the combination number,

press the  key and enter the number of items desired in the combination, or press the  key to allow any combination quantity.

Example: 3 items

Press  3

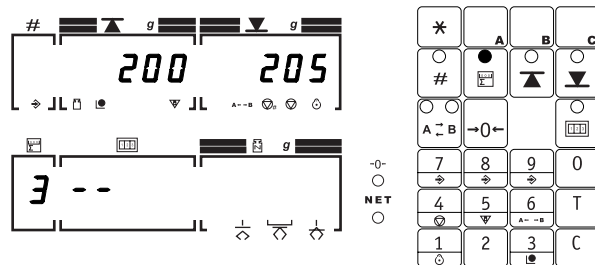

## II Operating Parameters

### II.A Setting Parameters

4. Press the  key to return to weighing mode.

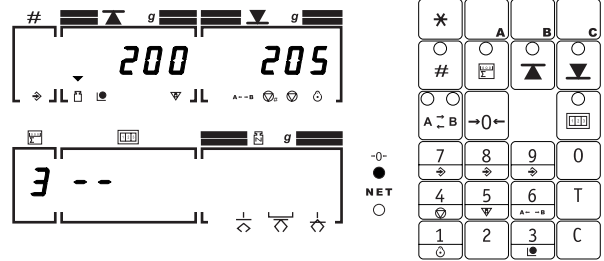

Note: The lower limit, upper limit and combination quantity may each be set without resetting any of the others by pressing the appropriate access key:







 ,  or  , entering the desired quantity

and pressing the  key to return to weighing mode.

If an error is made while entering data, press the

 key and enter the desired quantity.

### II.B Storing Parameters

1. Enter memory mode by holding the  key and pressing the  ,  and  keys. The  ,  and  symbols on the keypads and the display represent memory mode.

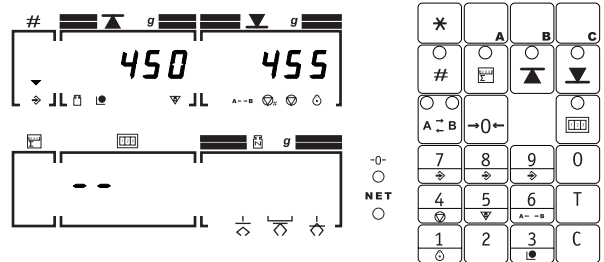

2. Enter the desired lower limit, upper limit and combination number (see section II.A.)

Example: 200 g, 205 g and 3 items

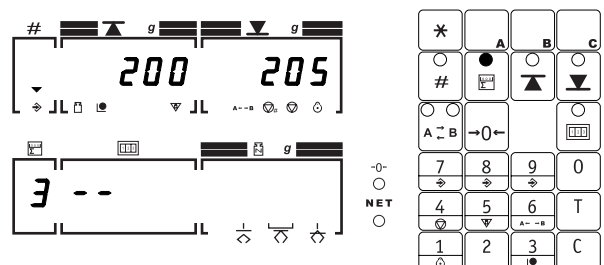

## II Operating Parameters

### II.B Storing Parameters

3. Select the desired memory register by pressing one of the direct access keys (A, B or C), or by pressing the  key and then one of the numeric keys (0 - 9.)

Example: register 5

Press  

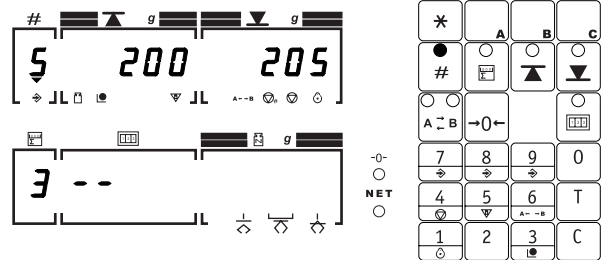

4. Enter additional parameter sets for other memory registers or press the  key to return to weighing mode.

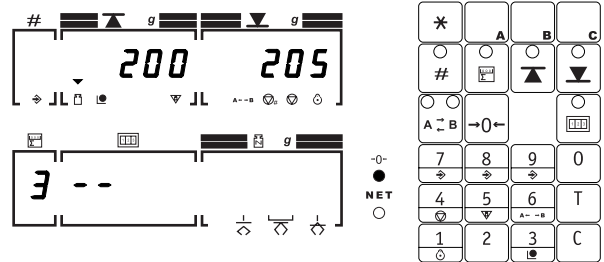



### II.C Recalling and Verifying Parameters

1. To recall stored data press the desired direct access key (A, B or C) or press the  key and the desired numeric key (0 - 9.)

Example: register 5

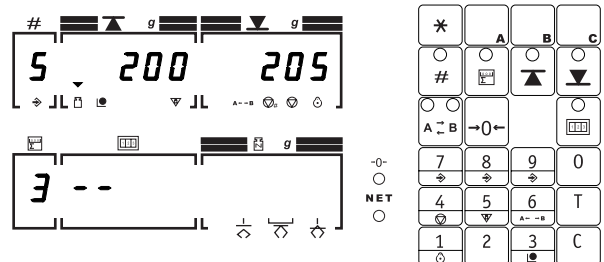
Press  



2. To cycle through all of the numeric (0 - 9) registers for parameter verification, press the  key twice. The data stored at register 0 is displayed.

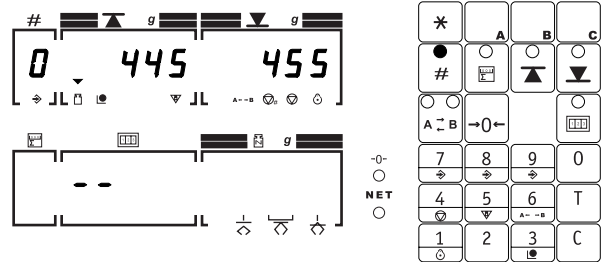

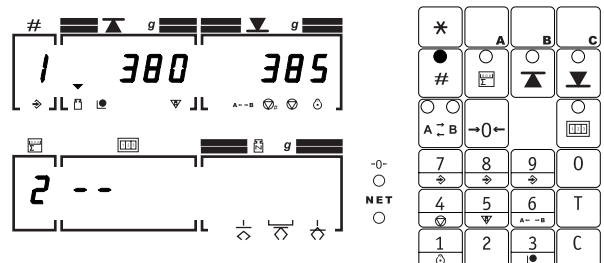

3. Press the  key again and the data stored at register 1 is displayed.



## II Operating Parameters



### II.C Recalling and Verifying Parameters

4. Repeatedly pressing the  key will cause the display to cycle through all of the numeric (0 - 9) registers.

5. Press the  key to return to weighing mode.



## III Operating Modes

The TDW-204W will select a combination within the lower and upper limits, and of the specified number of units, if one exists. The buzzer will sound once, the lights next to the selected scales will light until the item is removed, the combination weight will display and the accept indicator  will light. Remove the indicated items and put replacement items on the scale platforms. If an item is removed from a non-indicated scale, the buzzer will sound and the light next to the scale will flash. Place the item back onto the scale.



If such a combination does not exist and all platforms are occupied, the TDW-204W will select the nearest combination over the upper limit. This factory default can be changed to cause the TDW-204W to select either the nearest combination below the lower limit or the nearest combination, high or low, from the target range. When such a combination is selected the buzzer will not sound, the lights next to the selected scales will flash, the combination weight will display and the under  or the over  indicator will light. Replace any item with a smaller, for over weight, or larger, for under weight, item. A new combination will be recalculated automatically. Since the TDW-204W will not recognize changes below a set threshold, it may be necessary to lightly tap one of the scales to trigger a recalculation.

### III.A Combination Modes

#### III.A.1 Any Quantity

1. The scale must be in normal weighing mode, . If not, hold the  key and press the key with the symbol of the active mode.

Example: scale in priority mode, 

Hold  and press 

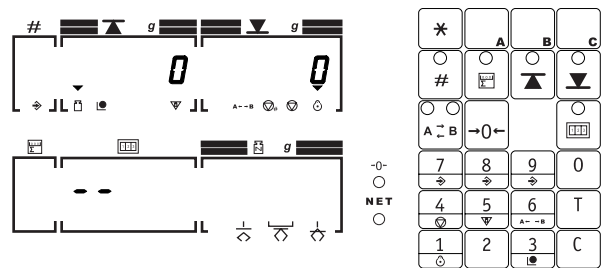

2. Enter the lower and upper limit parameters, and clear any combination number (see Chapter II.)

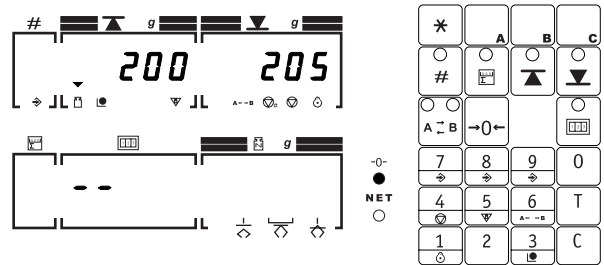

3. Place items on the scale platforms. Factory settings, that can be changed, require at least three scales to be loaded before calculation will begin. The TDW-204 will calculate a combination that weighs between the lower and upper limits with any number of items.

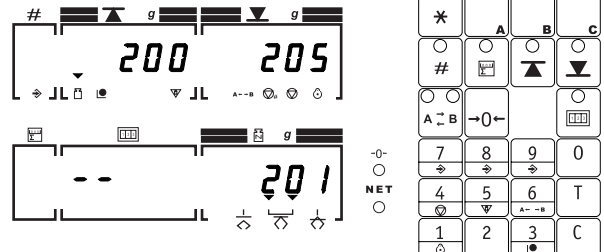

4. Remove selected items and replace them.

## III Operating Modes

### III.A Combination Modes

#### III.A.2 Set Quantity

1. The scale must be in normal weighing mode, . If not, hold the key and press the key with the symbol of the active mode.

Example: scale in priority mode, .

Hold and press .

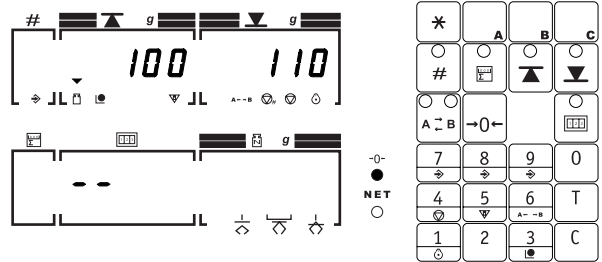

2. Enter the lower limit, upper limit and combination number parameters (see Chapter II.)

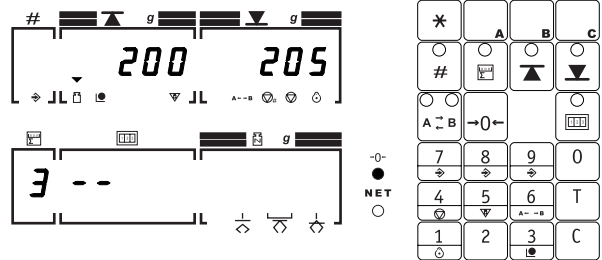

3. Place items on the scale platforms. Factory settings, that can be changed, require at least three scales to be loaded before calculation will begin. The TDW-204W will calculate a combination that weighs between the lower and upper limits with the specified number of items.

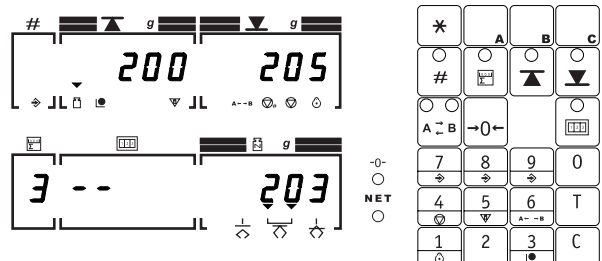

4. Remove selected items and replace them.

#### III.A.3 Priority Combination

Priority mode selects the items that will bring one of the units on the satellite scales (#1 and #7) to the target weight. The units on the satellite scales are the priority items. This mode is useful for "topping off" larger containers with smaller items. Priority mode will work in conjunction with all combination modes except sorting mode (see addendum.)

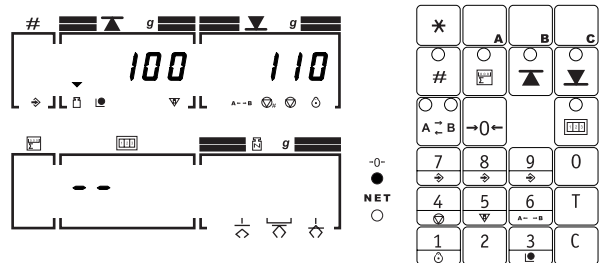

1. The scale must not be in sorting mode, . If it is, hold the key and press the key.



## III Operating Modes

### III.A Combination Modes

#### III.A.3 Priority Combination

2. Enter priority mode by holding the  key and pressing the  key.  is the symbol for priority mode.

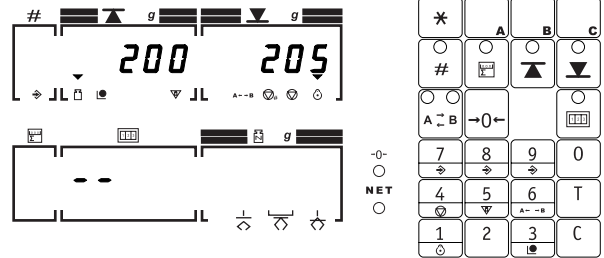

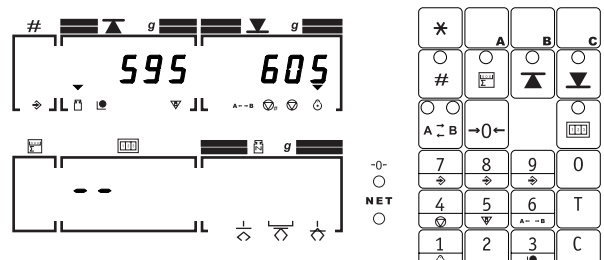

3. Enter the lower and upper limit parameters (see Chapter II.)

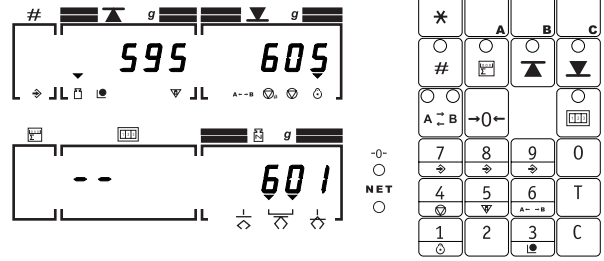

4. Place the priority containers on the satellite scales (#1 and #7) and the smaller items on the other scales. Factory settings, that can be changed, require at least three scales to be loaded before calculation will begin. The TDW-204W will calculate a combination that weighs between the lower and upper limits, and includes one of the priority containers.



5. Remove selected items and replace them.

6. Exit priority mode by holding the  key and pressing the  key.

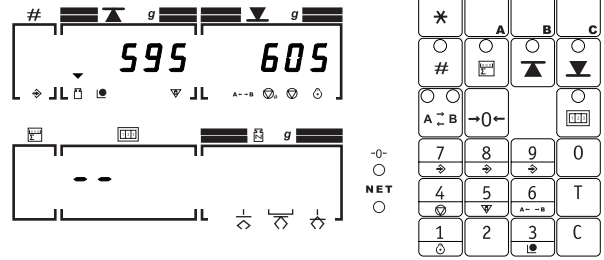

### III.B Sorting Mode



Sorting mode selects a specified number of items that weigh within a set percentage of each other. If you are interested in using the TDW in sorting mode, contact your dealer or our web site for the sorting mode addendum to this manual.

## III Operating Modes

### III.C Two Operator Mode

The TDW-204W can be split into two separate groups of scales. In this mode scales 1 through 6 are side B, and scales 7 through 12 are side A. This mode allows the scale to be used as two separate combination weighers, and is also very useful for packages that contain two mixed products. Each memory register will hold two full sets of parameters, one set for side A and another set for side B, that can be recalled independently of each other. All other operating modes (i.e. - combination, priority, batching) can be used in conjunction with two operator mode with the exception of sorting mode (see addendum.) Entering or exiting priority mode on one side will force both sides into or out of priority mode. The zero reset key will only function on the scales of the side that is selected for display.





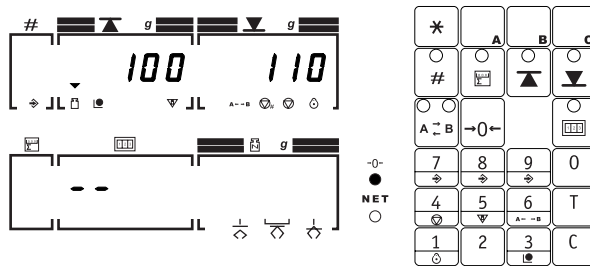

While in two operator mode, pressing the  key will cause the display to toggle between side A and side B. The indicator lamps on the key show which side is currently being displayed.

1. Enter two operator mode by holding the  key and pressing the  key.  $A \leftrightarrow B$  is the symbol for two operator mode. The  key shows side A is selected.



2. Select the desired mode and side, and enter the lower limit, upper limit and combination number parameters (see Chapter II.)

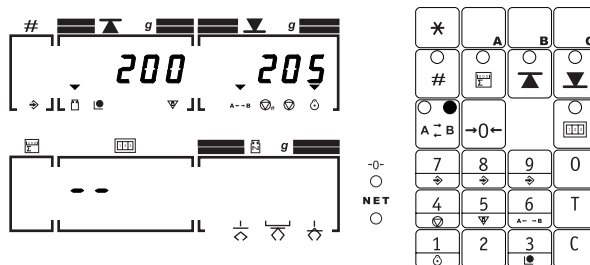

Example : priority mode, side B, 200 g, 205 g

Press     
 2 0 0  
 2 0  



3. Enter parameters for the other side.

4. Proceed as described in the section for the operating modes being used.

5. Exit two operator mode by holding the  key and pressing the  key.



## III Operating Modes

### III.D Consecutive Number/Batching



In consecutive number mode, the TDW-204W counts the number of combinations that have been made. When that number equals the entered batch number, the scale signals the end of the batch by sounding the buzzer and by suspending combination calculation until consecutive number mode is reset or until the scale is returned to normal weighing mode. Consecutive number mode can be used in conjunction with all other operating modes (i.e. - combination, priority, two operator and sorting - see addendum.)

1. Enter consecutive number mode by pressing the  key and enter the desired batch number with the numeric keys.

Example: 50 combinations

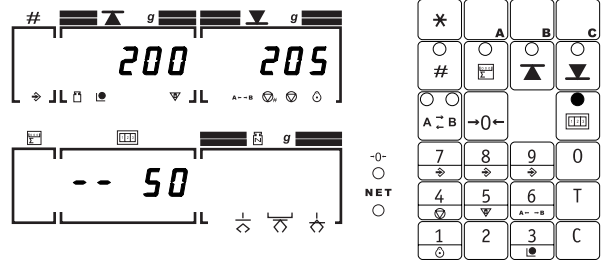
Press   



2. Press the  key to clear an entry. Press the  key to begin weighing.

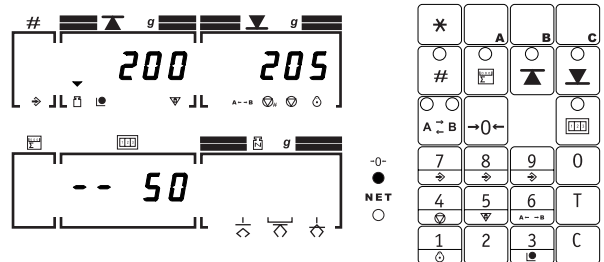

3. The indicator will count down from the batch number every time a combination is removed from the scales.

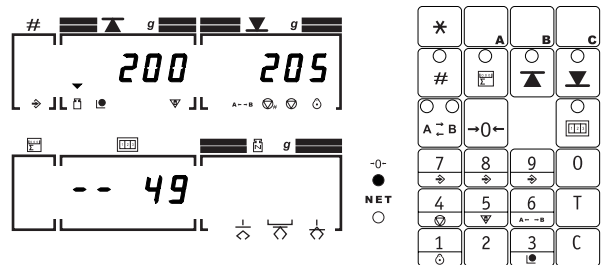



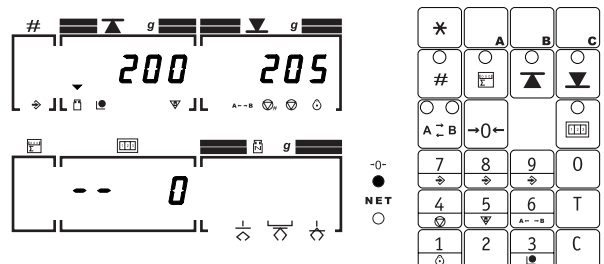

4. When the batch number reaches zero the buzzer will sound and the scale will suspend combination calculation.



## III Operating Modes

### III.D Consecutive Number/Batching



5. Reset the batch number to the previous value by pressing the  key.

6. Exit consecutive number mode by pressing the  key, the  key and the  key.



## IV Troubleshooting

### IV.A Checking the Scales

The individual scales can be read and verified by entering scale check mode. While in scale check mode, pressing the  key will only zero the selected individual scale.

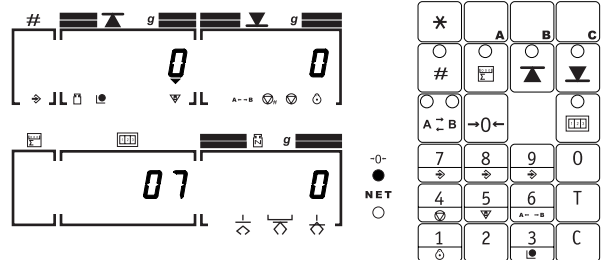
1. Enter scale check mode by holding the  key and pressing the  key.  is the symbol for scale check mode.



2. Scale number 7 will be displayed. To select another scale press the  key to scroll down or the  key to scroll up through the scales. The combination lamp of the selected scale will light.

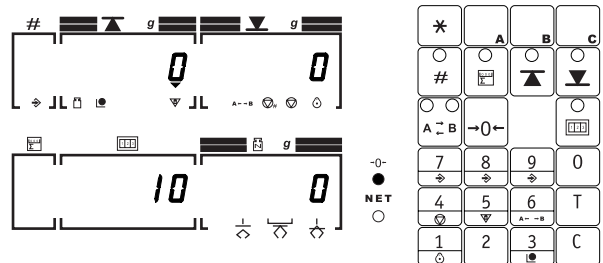

3. Place a known test weight on the desired scale and compare the known value to the displayed value.

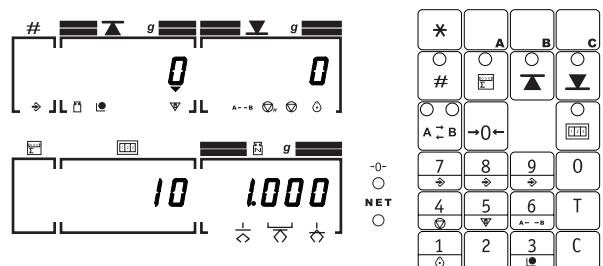



4. Exit scale check mode by pressing the  key.

## IV Troubleshooting

### IV.B Scale Suspension

A defective scale must be removed from operation so that its output is not included in the combination calculations. When unstable weight readings are received from a scale over five time intervals, that scale is automatically suspended. The  indicator shows that one or more scales are suspended. This section illustrates how to suspend a scale, how to determine which scales are suspended and how to remove a scale suspension.

#### IV.B.1 Suspending a Scale

1. Enter scale suspension mode by holding the  key and pressing the  key. # is the symbol for scale suspension mode.

Example: scale #5 reads zero error plus

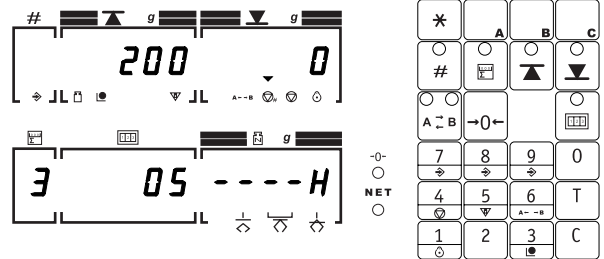
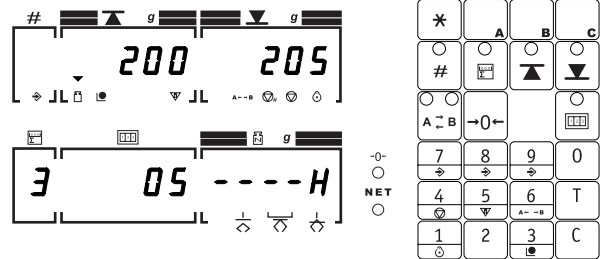



2. Enter the number of the scale to be suspended with the numeric keys.

Example: scale #5

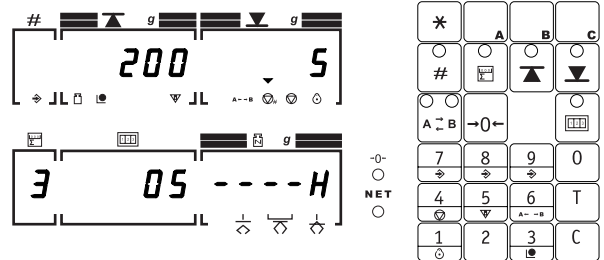
Press 



3. Press the  key to suspend the selected scale and return to normal operating mode. The  indicator shows a scale is suspended.

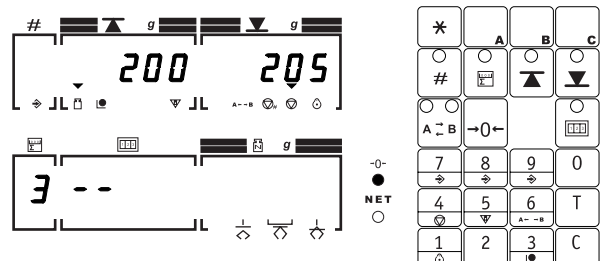

4. Each scale suspension must be entered separately by repeating steps 1 through 3.

## IV Troubleshooting



### IV.B Scale Suspension

#### IV.B.2 Identifying and Clearing Suspended Scales

1. Enter scale suspension mode by holding the

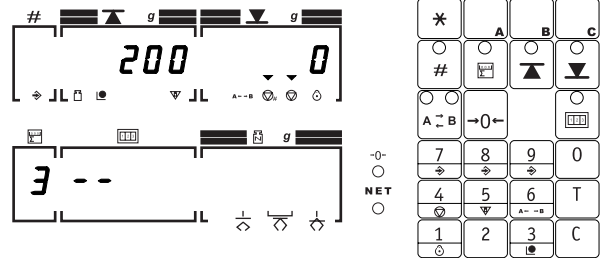
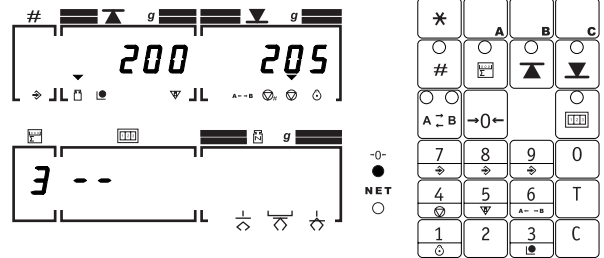
 key and pressing the  key.



2. Press the  key to scroll down or the  key to scroll up through the suspended scales.

Example: scale #5 is suspended

Press  or 

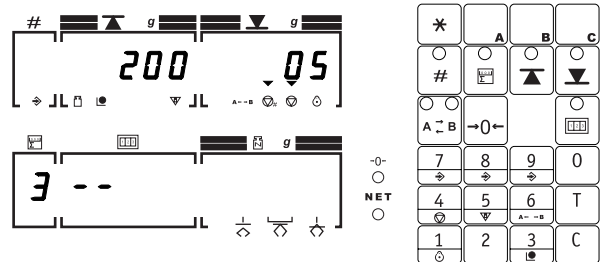

3. Press the  key to remove a scale suspension.

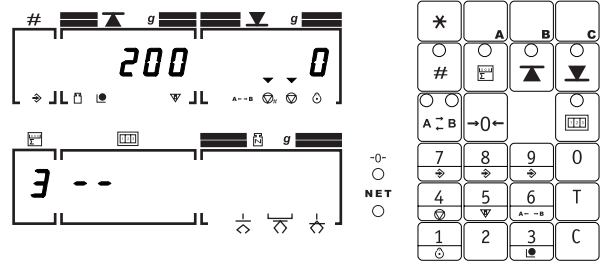

4. Exit scale suspension mode by pressing the

 key.

## IV Troubleshooting

### IV.C Error Messages

Before making a service call, please check that power is supplied to the TDW-204W, that all cables are correctly and securely connected, and that the following corrective actions have been performed. Please have the serial number and rated capacities of your TDW-204W available when contacting your dealers service department.

The number of the scale with the error is indicated in the consecutive number window. In each of the following examples, scale #9 is the scale indicated. The error code is indicated in the combination weight window.

#### Initial Error - H

Error message "H" appears upon power up if the initial value of a scale exceeds the allowable zero range.

Remove all items from the scale platform and ensure the platform stop screws were removed during setup. Cycle the power off and back on.

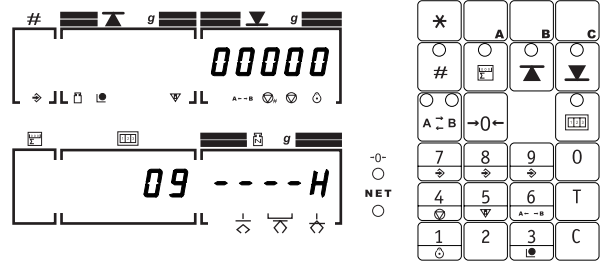

#### Initial Error - L

Error message "L" appears upon power up if the initial value of a scale is below the allowable zero range.

Remove any items wedged under the scale platform and ensure the platform stop screws were removed during setup. Cycle the power off and back on.

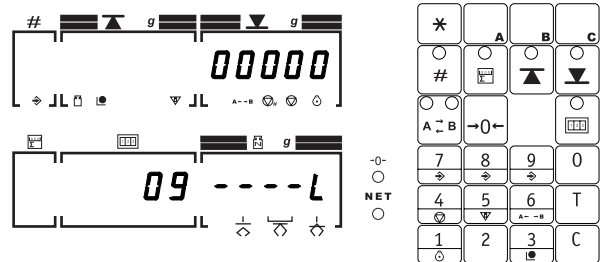

#### Zero Error - H

Error message "H" appears when the  key is pressed if the value of a scale exceeds the allowable zero range.

Remove all items from the scale platform.

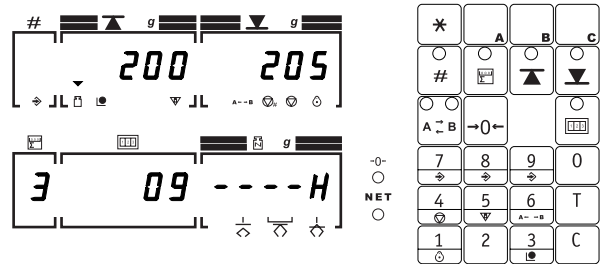

#### Zero Error - L

Error message "L" appears when the  key is pressed if the value of a scale is below the allowable zero range.

Remove any items wedged under the scale platform.

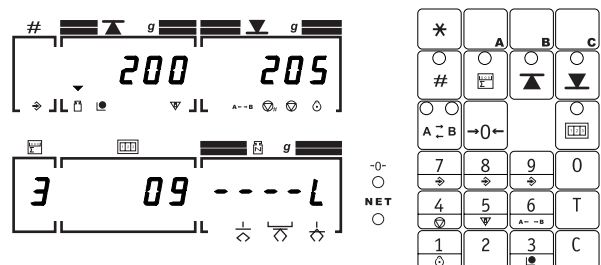

## IV Troubleshooting

### IV.C Error Messages

#### Overscale Error

Error message "OF" appears if the load on a scale exceeds three graduations above the rated capacity.

Remove all items from the scale.

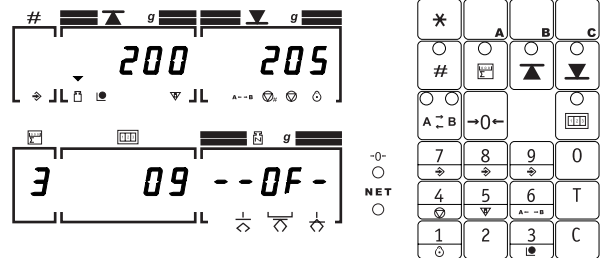

#### Combination Range Error

Error message "----" appears if no combination exists within a range of upper and lower limits.

Replace a heavier item with a lighter item or a lighter item with a heavier item.

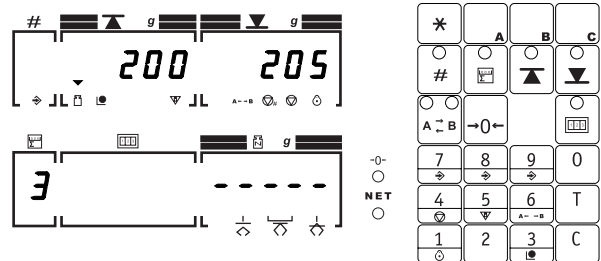

The following error messages are displayed in the combined weight window. If one of the following error messages is displayed, cycle the power off and then back on. If no error message is displayed, the scale is ready for use. If the error message is repeated or if error messages are displayed frequently, contact your dealer's service department.

When unstable weight readings are received from a scale over five time intervals, that scale is automatically suspended.

Err01 EEPROM write error

Err02 EEPROM check error

Err03 RAM error (OIML Check enabled)\*

Err04 ROM error (OIML Check enabled)\*

Err05 EEPROM read error

Err06 A/D conversion error

Err07 Unstable weight readings were received from three or more scales simultaneously within a set time.

Err08 Three or more scales have been automatically suspended for unstable weight readings. The scales must be removed from suspension (see Section IV.B.2) before operations may resume.

## IV Troubleshooting

### IV.C Error Messages

Err09 Both priority scales (#1 and #7) have unstable weight readings. The priority scales must be removed from suspension (see Section IV.B.2) before operations may resume. The TDW-204 may still be used in other modes without removing the suspensions.

Err10 RS232C data transmission error. Check keywords 7 through 10.

Err11 A conflict exists between the scale interval settings for the main scales (keyword = = = 21) and the satellite scales (keyword = = = 23.) Correct the keyword settings.

Err12 A/D conversion circuit failed maximum capacity check (OIML Check enabled)\*

\* Error messages 3,4 and 12 are enabled when keyword = = = 35 (OIML Check) is set to 1.

## V Appendices

### V.A Specifications

#### Physical Dimensions

##### Large Model

	Control Panel	Main Scale	Satellite Scale	
		3 kg/6 lb	3 kg/6 lb, 6 kg/15 lb, 15 kg/30 lb	with roller conveyors 15 kg/30 lb
W(mm)	345	960	200	350
D(mm)	95	740 (370 x 2)	740 (370 x 2)	740 (370 x 2)
H(mm)	287	123.5	123.5	151.5

##### Small Model

	Control Panel	Main Scale	Satellite Scale
		3 kg/6 lb	3 kg/6 lb, 6 kg/15 lb, 15 kg/30 lb
W(mm)	345	760	160
D(mm)	95	540 (270 x 2)	540 (270 x 2)
H(mm)	287	123.5	123.5

#### Scales

##### Kilogram and gram models

	Main Scales	Satellite Scales		
Load Cell	Strain Gage Load Cell			
Capacity	3 kg	3 kg	6 kg	15 kg
Quantity	10	2	2	2
Minimum Graduation	1 g	1 g	2 g	5 g
Maximum Tare	3 kg	3 kg	6 kg	15 kg
Platform Width (mm)	160, 175	160, 175	160, 175, 350*	160,175, 350*
Platform Depth (mm)	195, 275	195, 275	195, 275, 240*	195, 275, 240*

\* Dimensions with optional roller conveyors.

##### Pound models

	Main Scales	Satellite Scales		
Load Cell	Strain Gage Load Cell			
Capacity	6 lb	6 lb	15 lb	30 lb
Quantity	10	2	2	2
Minimum Graduation	0.002 lb	0.002 lb	0.005 lb	0.01 lb
Maximum Tare	6 lb	6 lb	15 lb	30 lb
Platform Width (mm)	160, 175	160, 175	160, 175, 350*	160, 175, 350*
Platform Depth (mm)	195, 275	195, 275	195, 275, 240*	195, 275, 240*

\* Dimensions with optional roller conveyors.

## V Appendices

### V.A Specifications

#### Combinations

	Satellite Scales		
	3 kg/6 lb	6 kg/15 lb	15 kg/30 lb
Combination Range	0.04 - 18 kg 0.08 - 36 lb	0.08 - 21 kg 0.2 - 45 lb	0.2 - 30 kg 0.4 - 60 lb
Minimum Increment	1 g 0.002 lb	2 g 0.005 lb	5 g 0.01 lb
Weighing Range	0.02 - 3 kg 0.04 - 6 lb	0.04 - 6 kg 0.1 - 15 lb	0.1 - 15 kg 0.2 - 30 lb

**Power Requirements** 100/115/200/220/230/240 VAC +/- 10%, 50 - 60 Hz, 15 VA

**Operating Temperature** 0 C ~ 40 C

**Water Resistance** IP-65

#### Display

Console Fluorescent tubes  
Combination Lamps LED

#### Functions

Combination by weight  
Combination by quantity  
Optimum combination  
Priority combination  
Two operator weighing (A-B row combination)  
Consecutive number/batching  
Sorting (see addendum)  
Storage and recall of thirteen parameter sets  
Automatic recalculation  
One touch tare  
Scale checking  
Defective scale suspension

#### Options

RS-232C communications  
Roller conveyors

## V Appendices

### V.B Drawings

#### Small Model

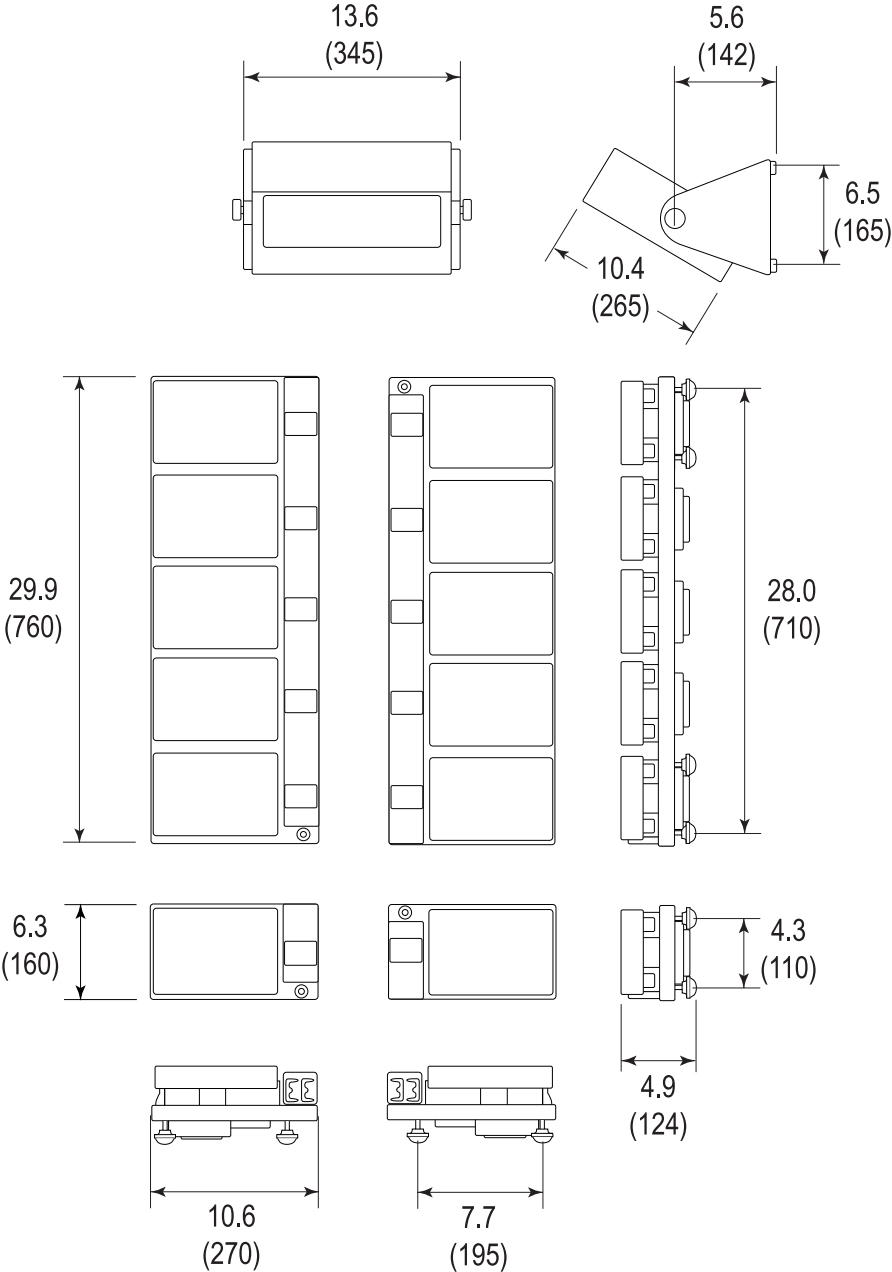

## V Appendices

### V.B Drawings

#### Large Model

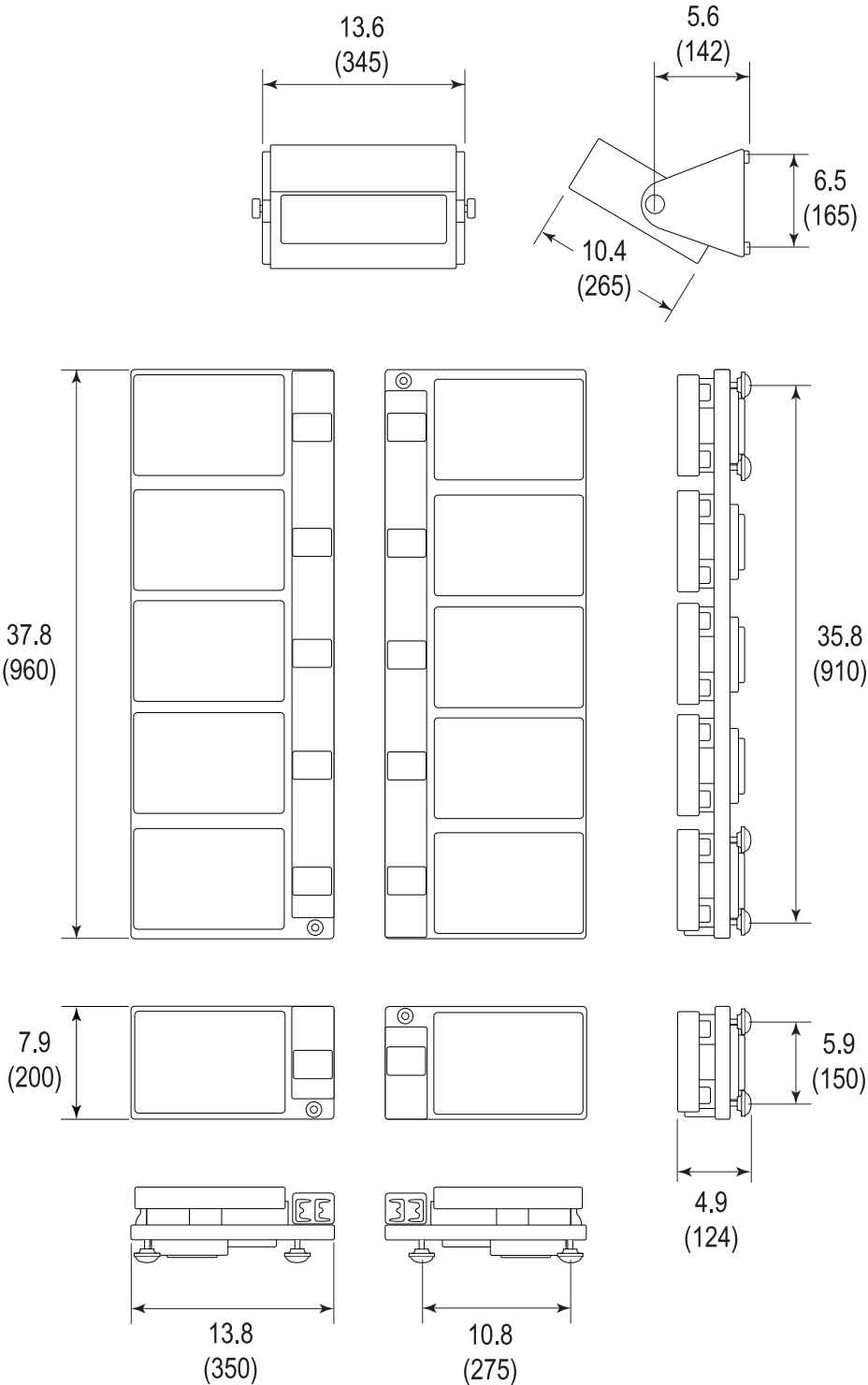

## V Appendices

### V.B Drawings

#### Large Model with Optional Roller Conveyor

