

Yamato

Semiautomatic Table-top **Dataweigh**TM

TSDW-205
TSDW-205W

Instruction Manual

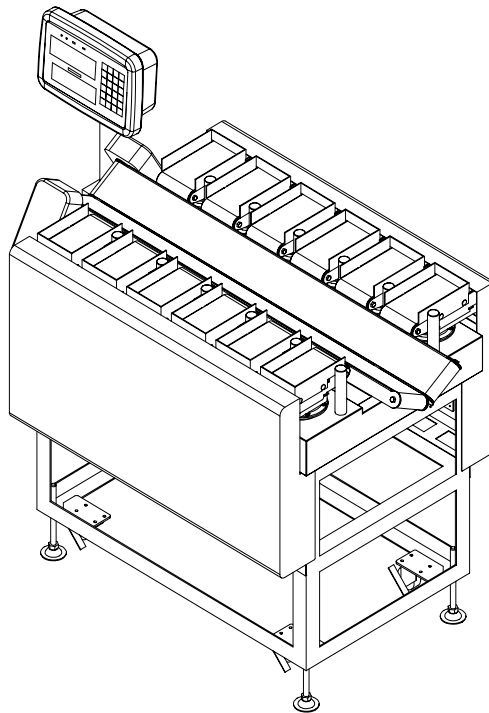

Yamato Scale Co., Ltd.

Introduction:

Thank you very much for purchasing the tabletop type Dataweigh "TSDW-205/ TSDW-205W".

Please read this instruction manual thoroughly to use this machine correctly.

- Be sure to read "For your safety use" (Page 2) and "Precautions for use" (Page 5) before using the machine.
- Be sure to keep this instruction manual in a convenient place so as to be available at any time.

February, 2012

Contents



1.	For your safety use	3
2.	Precautions for use	6
3.	Start-up inspection, storage and disposal	9
4.	Part names and functions	10
5.	How to mount and dismount the conveyor belt and base	11
6.	Installation	14
7.	Display panel and key operation	14
8.	Key operation	15
9.	About the display	17
10.	Available functions	22
11.	How to turn on power	23
12.	How to turn off power	24
13.	Emergency stop switch	24
14.	Weight combination function	25
15.	All discharge function	26
16.	Operation of scale functions	26
17.	Setting of the conveyor speed	29
18.	Setting of discharging mode	30
19.	How to input item name	31
20.	How to register items	32
21.	How to call up item data	33
22.	How to clear item data	33
23.	Priority combination function	34
24.	Quantity combination function	35
25.	Upper/lower limit discriminating function	36
26.	Proximity combination and auto recombination functions	39
27.	Exchange instruction function	40
28.	Remain detecting function	41
29.	Target value setting function	42
30.	Suspended scale function	44
31.	Scale check function	45
32.	Other function setting	48
33.	How to set the date and time	50
34.	How to adjust the display brightness and contrast	51
35.	How to confirm the indicator software version	52
36.	How to set user parameters	53
37.	User parameters table	55
38.	Error display	57
39.	Specifications	60

1. For your safety use

Read "For your safely use" and the "Instruction Manual" thoroughly before using this product, and use it correctly.

After you read it, keep it with care so as to be available whenever you need it.

Marks used in this manual and the meanings:

	Danger:	Indicates operations without complying with the instruction may result in fatal or serious injury.
	Warning:	Indicates operations without complying with the instruction may result in bodily injury or damage of properties
	Caution:	Indicates operations without complying with the instruction or correcting your practice may result in damage of the entire product.

Warning marks



High voltage

This mark indicates high voltage. Touching may cause a serious or fatal inquiry. Be sure turn off power at inspection or maintenance.



High temperature

This mark indicates high temperature. Touching the part may cause a serious or fatal inquiry. Be sure not to touch to this part during operation and until machine is cooled down after operation..



Rotating part

This mark indicates rotating. In case of touching the part, fingers or clothes can be caught into machine. Be sure not to open the cover during operation. If necessary, arrange a qualified staff for such a work.



Moving part

This mark indicates the part will move. Touching to the part, it will cause serious injury by getting stuck in the machine.. Be sure not to touch the part over safety guard during operation. If necessary, arrange such a work by a qualified staff.



Prohibit

It includes prohibition of particular actions. Avoid such behave, otherwise, it will cause serious damage for your facilities.



Danger: Choose carefully the installation place.

Be sure to install the machine and peripheral facilities horizontally on the base ground with enough intensity to support them. Installation on unstable or inclined floor will result in serious accident such as toppling down of the machine.

Also, secure enough brightness for work place for safety, efficiency in operation and service/maintenance



Danger: To prevent explosion and flashing accident

This machine is not explosion-proof.

Do not use it in an area where inflammable gas or hazardous substances exist.



Danger: To prevent electric shock

1. To prevent serious injury caused by electrical leak, be sure to connect an earth wire. The power plug uses a 3P plug with an earth terminal. When the wall socket to be used is 2P, use a 3P/2P conversion socket, and connect an earth wire to it.
2. Do not step or let the wheel of cart pass on the power cable.
3. Never remove any screw on the display panel.
4. Hold firmly the resin part of the plug whenever connecting/disconnecting the power plug.
5. Do not put wet hands, wet cloth and or metallic parts into the machine.
6. Do not attempt to disassemble or modify this product.
7. Be sure to turn off power before washing, otherwise it will cause a serious electric shock as well as a machine trouble. (TSDW-205W only)



Danger: To prevent fire and electric shock

Using it in such an abnormal situation as there is smoke or unusual smell may result in fire and/or electric shock.

Disconnect immediately the power cable plug from a wall socket.

Check that the smoke has ceased, and then request your distributor for repair.

Never repair it by yourself. It is dangerous.



Caution: Do not lift up the indicator and or conveyor

The indicator or conveyor may get disconnected and fall down, which will result in a serious accident. An unusual force may be applied to the scale, which may result in failure.



Caution: Do not insert you hand or finger into the clearance of the scale

Do not insert your hand or finger into the clearance of the scale.

Otherwise, it may result in bodily injury or failure.

An unusual force may be applied to the scale, which may result in failure.



Caution: Do not carry without securing safety

Be sure to verify the safety when you carry or relocate the machine.

Do not carry the machine in an unstable posture or by holding the controller of the machine.



Caution: Do not detach the conveyor before switching off power.

Be sure to turn off power before detaching the conveyors. Otherwise, the conveyor may be suddenly activated and will cause serious accident.



**Caution: Do not activate the machine without mounting the conveyor cover.
(TSDW-205W only)**

Do not activate the machine before mounting the conveyor cover. Otherwise, conveyor may be suddenly activated and will cause a serious injury by pinching accident.



Caution: Do not wash the machine in water. (TSDW-205 only)

The TSDW-205 is NOT waterproof construction. Never wash the machine in water.



Caution: Ensure pre-start check.

Skipping this process will cause problem in conveyor drive or work efficiency
Be sure to verify the safety when you carry or relocate the machine.



Caution: Do not place other things than the items to be weighed

It will cause a machine trouble by dragging or trapping.

2. Precautions for use

To prevent failure, comply with the following:

- (1) The machine is waterproof construction, but refrain from directly pouring pressured water onto it. (TSDW-205W)

The machine is NOT waterproof construction, so do not wash it in water. (TSDW-205)

- (2) Do not wash the machine with hypochlorous acid or alcohol. As to the conveyor belt and guide which do not directly touch foods, spray wash with neutral detergent or alcohol of 400ppm or less chloride concentration is usable. (TSDW-205W)

Do not wash the machine with hypochlorous acid or alcohol. (TSDW-205)

- (3) This machine is a precise electric device. Do not apply a rapid temperature change to the machine, or do not store it in any place with high humidity.
- (4) Do not damage the power cable and do not place a heavy load on it, pull it, nor break it.
- (5) Do not hit the display screen (display, switch) with your nail or other sharp tools.
- (6) When moving the machine, be sure to ground the caster by screwing up support legs to the end and move the machine gently without giving shock or vibration. Also, hold the bottom of the machine by both hands with two or more persons to carry or relocate the machine, so as not to fall or bump it onto the floor.
- (7) Do not fall the indicator on the conveyor or do not apply a shock or vibration to it.
- (8) Do not wipe the machine with thinner or benzin.
- (9) Never disassemble or modify the machine. Otherwise your hand may be injured by internal components.
- (10) Do not use the machine in any place exposed to sand, dust, and powder, salt water and/or sea breeze.
- (11) Do not give chilly air as it may generate condensation inside of the machine.
- (12) Do not store the machine in any place where the temperature is high or changes rapidly.
- (13) When the machine is operated in the circumstance where condensation is apt to generate, move the machine to the place under dried atmosphere to store after operation.

The following may cause incorrect measurement:

- (1) Do not use the machine in any place close to fire or steam, or subjected to direct sunlight or air conditioner wind.
- (2) Do not install the machine close to equipment generating excessive shocks, vibration, or strong electromagnetic waves (microwave oven, mobile telephone, etc.).
- (3) Install the machine on a flat and stable floor strong enough to withstand the load.
- (4) Use the machine in the specified environment.
(Operating environment: 0°C to +40°C, 30% to 85% RH)
Do not expose it to a rapid temperature change.
Do not use the machine for a long period of time in a high humidity environment.
- (5) Do not use the machine on an inclined or unstable stand (shaky stand).
- (6) Use the machine in the stable circumstance where black out or excessive surge will unlikely happen.
- (7) Do not operate when there is foreign materials on the scales or in the space between scales.
- (8) Place the weighed item at the center of the weighing conveyor.

To maintain the scale performance (TSDW-205W):

- (1) Clean the indicator with a wet cloth, and then completely wipe off the water with a dry cloth. Do not pour water to the indicator.
- (2) Clean the main body and the conveyors with wet cloth, and then completely wipe off the water with a dry cloth. When using water, do not wash it by pressured water spray but by gently pouring water. Do not use seawater, unclean water, water containing impurity, hot water or cold water which has temperature gap more than 5°C from the room temperature.
- (3) Use a soft cloth or sponge for wiping off main body or the conveyors. Do not use a hard brush.
- (4) Dilute a neutral detergent 200 times with water and wipe the conveyors with a sponge moistened with it. Then, flash them with clean water and wipe off the water with a dry cloth.
- (5) Clean the display only by wiping-off and do not wash it with chemicals.
- (6) Use hypochlorous only for sterilizing the belts and guides of conveyor, and never use it for the display panel or the main body of conveyor. After the belts and guides of conveyor are sterilized with hypochlorous acid, flush them with clean water and completely wipe off the water with a dry cloth.
- (7) Never disassemble or modify the machine. Should you disassemble it accidentally, be sure to contact your distributor.
- (8) Do not fall or bump the conveyors onto the floor. Should you fall or bump the machine onto the floor accidentally, be sure to contact your distributor.
- (9) Disconnect the power plug from a wall socket, when you do not use the machine for a long period of time.
- (10) Do not use the machine under the power condition where instantaneous shutdown or voltage change occurs.
- (11) Do not damage the display, switches, rubber part of indicator by hitting with a sharp tool or pressing with your nail or some cloth. Otherwise, its water proof performance may be deteriorated.

*For troubles arisen due to wrong use, repair will be charged even during warranty period.

To maintain the scale performance (TSDW-205):

- (1) Clean the machine with a wet cloth, and then completely wipe off the water with a dry cloth. Do not pour water to the indicator.
- (2) Cleaning with detergent, hypochlorous acid (400ppm or less), alcohol or hot water (40°C or less) can be applicable to only the belt of conveyor. Do not use these materials for cleaning the other part. Do not use boiled water or steam even for conveyor. After sterilizing the belt of conveyor with hypochlorous acid, flush them with clean water and completely wipe off the water with dry cloth.
- (3) In case of using the sponge type belt for the collating conveyor, mop it up it with well squeezed close and then completely wipe off the water with dry cloth.
- (4) Do not fall or bump the conveyors onto the floor. Should you fall or bump the machine onto the floor accidentally, be sure to contact your distributor.
- (5) Disconnect the power plug from a wall socket, when you do not use the machine for a long period of time.
- (6) Do not use the machine under the power condition where instantaneous shutdown or voltage change occurs.
- (7) Do not damage the display, switches, rubber part of indicator by hitting with a sharp tool or pressing with your nail or some cloth. Otherwise, its water proof performance may be deteriorated.

*For troubles arisen due to wrong use, the repair will be charged even during the warranty period.

3. Start-up inspection, storage and disposal

Recommendation of inspection at start-up

Appropriate measurement is required under the Measurement Law. Conduct of inspection and weight check at the start-up is recommended.

Storage and disposal

Storage area

1. Do not store the scale in any place subjected to high temperature, high humidity, or direct sunlight for a long time.
Significant change of the ambient temperature may cause malfunction due to internal condensation.

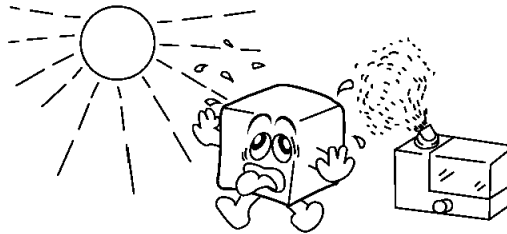

2. The main body is a precise electric device; therefore, do not store it in any place where shocks or vibration are applied, or likely applied.

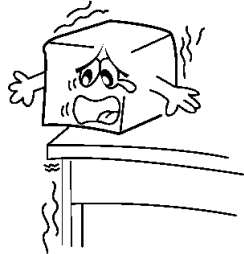

Disposal

This unit shall be disposed of as industrial waste (non-combustible waste).
Dispose it of appropriately according to the disposal instruction specified by the local government concerned.

4. Part names and functions

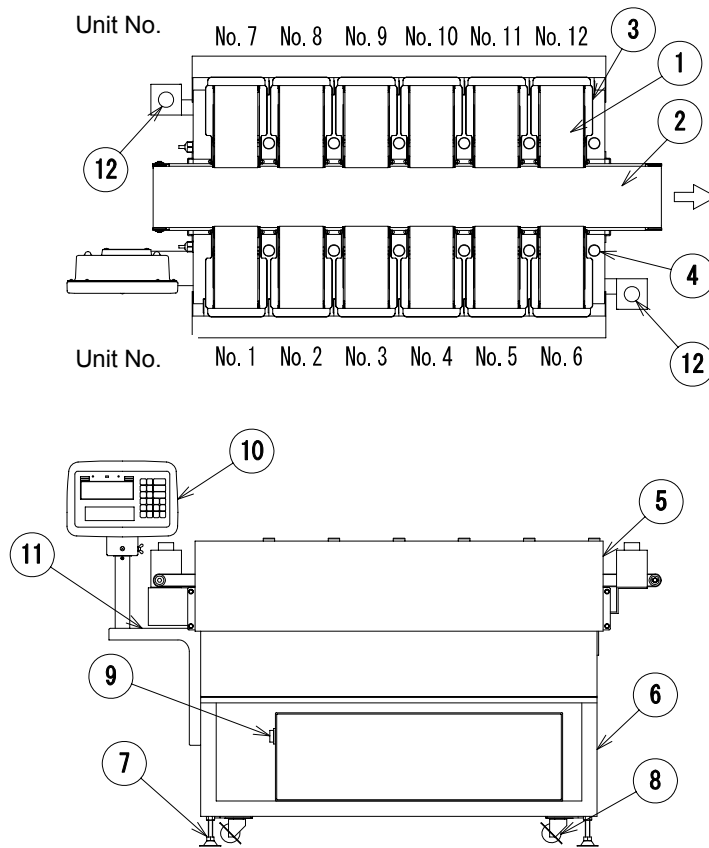

No	Name	Function
①	Weighing conveyor	Weigh placed items (This part is supplied with being dismantled. Refer to P10 for mounting.)
	Weighing conveyor base (Detachable/TSDW-205W only)	Mounting base of the weighing conveyor. (This part is to be mounted under the weighing conveyor and is supplied with being dismantled.)
②	Collating conveyor	Convey combined items Flat conveyor or V-shaped conveyor is available.
③	Conveyor guide	Guide for placing items on weighing conveyor
④	Signal lamp	Alarm on error and signal on using functions
⑤	Conveyor cover (TSDW-205W only)	Cover for the gear sector of conveyor. Be sure to mount the cover before activating the machine.
⑥	Base	Base frame of the main body. When moving the machine, hold this part.
⑦	Leveling leg	Adjust the machine height and horizontal situation.
⑧	Caster	For moving, these parts are to be grounded by screwing up support legs.
⑨	Breaker	Main power
⑩	Indicator	For operation, setting and display
⑪	Spirit level	Adjust the horizontality of machine at installation
⑫	Emergency switch	For emergency stop

*Accessories included in the package are an instruction manual and a M6 wrench for installation and dis-installation of Conveyor cover and Weighing conveyor support units.

5. How to mount and dismount the conveyor belt and base

(1) How to attach and detach the belt of weighing conveyor

1. Turn off the breaker

(Refer the position to No.9 in P8.)

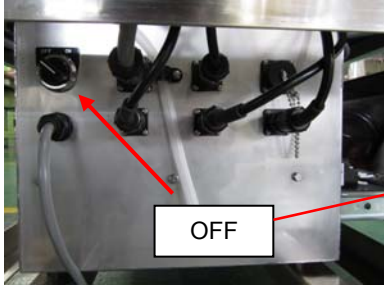

(TSDW-205W)



(TSDW-205)

4. Fold the weighing conveyor

(Hold the both end and fold it.)



2. Remove the conveyor guide

(Pull it up and remove.)

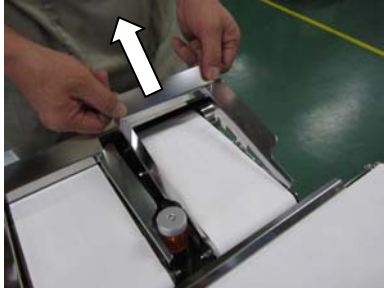

5. Remove the conveyor belt



3. Remove the weighing conveyor

(Lift up the front part and remove.)

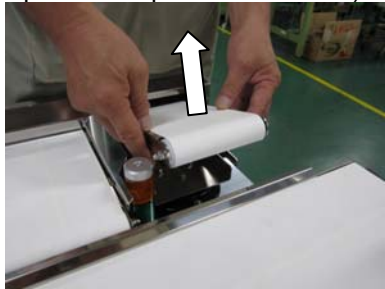

6. Mount the weighing conveyor

After setting the belt on the conveyor, mount it onto the main body with the angle shown in picture below.

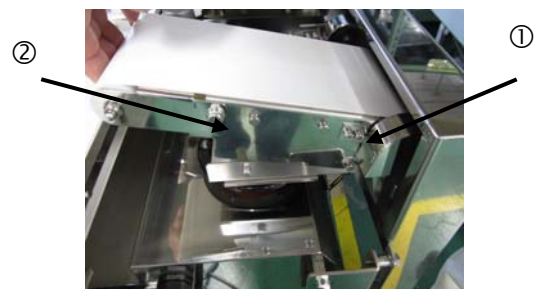

Note) When assembling the weighing conveyor, set the belt onto the conveyors so that the convex bank of the belt fits in the concave on the pulley.



Concave on the pulley

Convex bank on the belt

Note) When mounting or dismounting, make it gently to avoid excessive load onto the weighing conveyor.

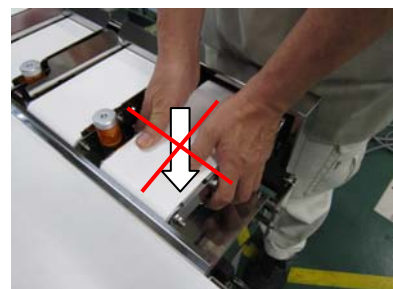

(2) How to mount and dismount the weighing conveyor base (TSDW-205W only)

1. Remove the conveyor cover

Screw off the bolt of conveyor cover with the accessory wrench. Hold the cover not to drop.



2. Remove the bolt of the weighing conveyor base

Screw off only the center bolt with accessory wrench. Do not remove side bolts.



3. Remove the conveyor mounting base

Lift up the base and remove it.

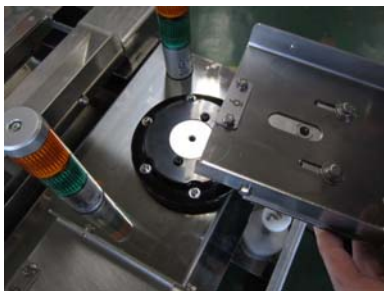

4. Check the unit No. of the base

Each mounting base is numbered for its position. Refer to page 9 and place the base at the place of the corresponding number.



5. Adjust the positioning of motor driving pin

Adjust the positioning of the motor drive pin and the plastic receptor not to touch each other.

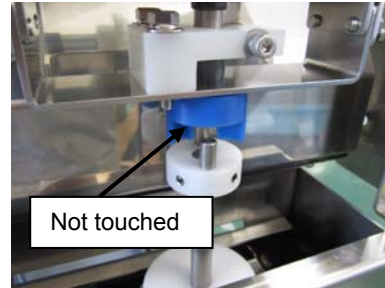

GOOD

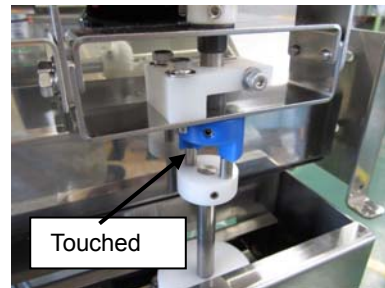

NOT GOOD

6. Place the conveyor mounting base

Place the base so that the screw holes of body and the base come to the same position.

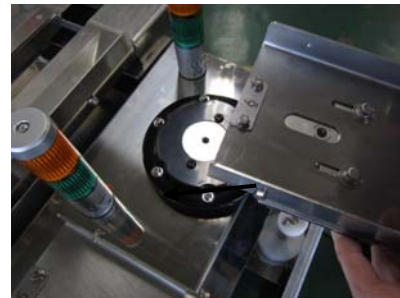

7. Fix the base by fastening the bolt

Fix the base by fastening the bolt. Do not fasten too tight.



(3) How to attach and detach the belt of collating conveyor

1. Switch off the breaker

Refer the position of breaker to No. 8 of page 9.

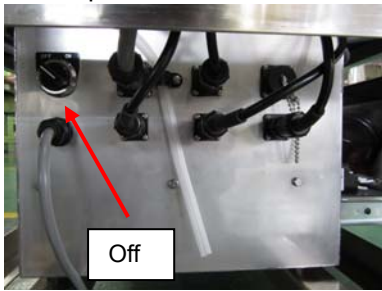

TSDW-205W

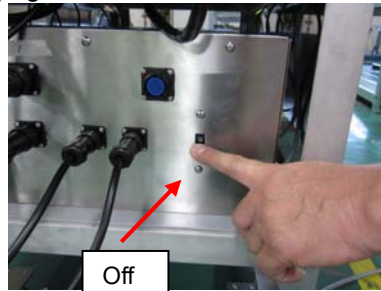

TDW-205

2. Lift up the collating conveyor

Lift up the gear side first and then lift up exit side.

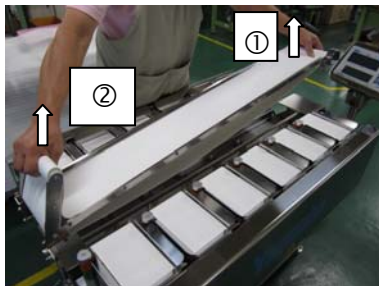

3. Remove the collating conveyor



4. Mounting the weighing conveyor

After putting the fitting of conveyor's exit side into the square hole of mounting base, place the conveyor to fit into the roller catch of gear side.

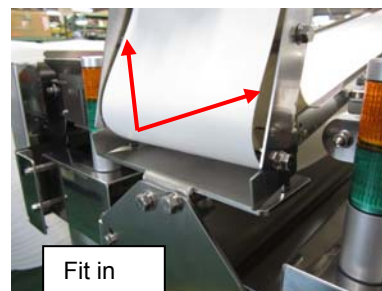

Note) When assembling the collating conveyor, set the belt onto the conveyor belt so that the convex bank under the belt fits into the concave on the pulley.

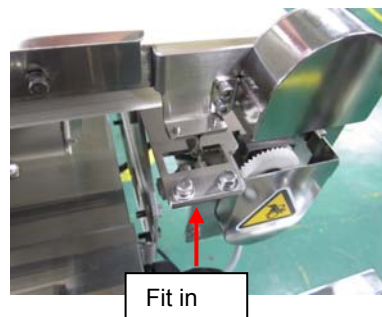
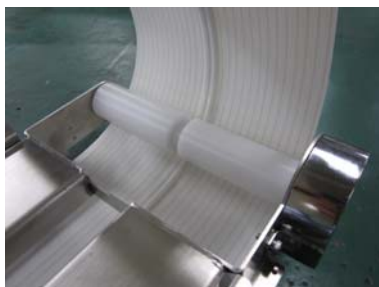

6. Installation

Whenever using the machine, be sure to install it horizontally. Otherwise, correct measurement cannot be performed. Also, a rattling base is inappropriate for correct measurement.

Cautions: Do not place it on an inclined floor (when it is beyond the adjustable level range).

Also, do not place it on an unstable stand.

There are 4 level adjusters on the bottom of the main body to adjust the level.

Place the machine on the flat floor as much as possible and adjust the horizontality with leveling leg adjusters so that the bubble of spirit level can be observed at the center of the reference circle. In addition, adjust the level adjuster so that all of them sit firmly on the stand.

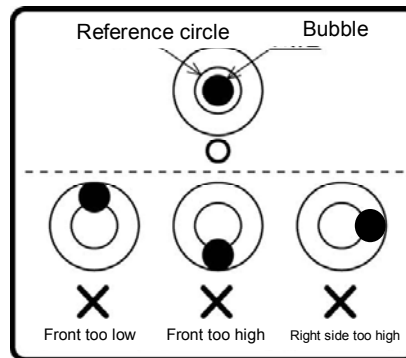



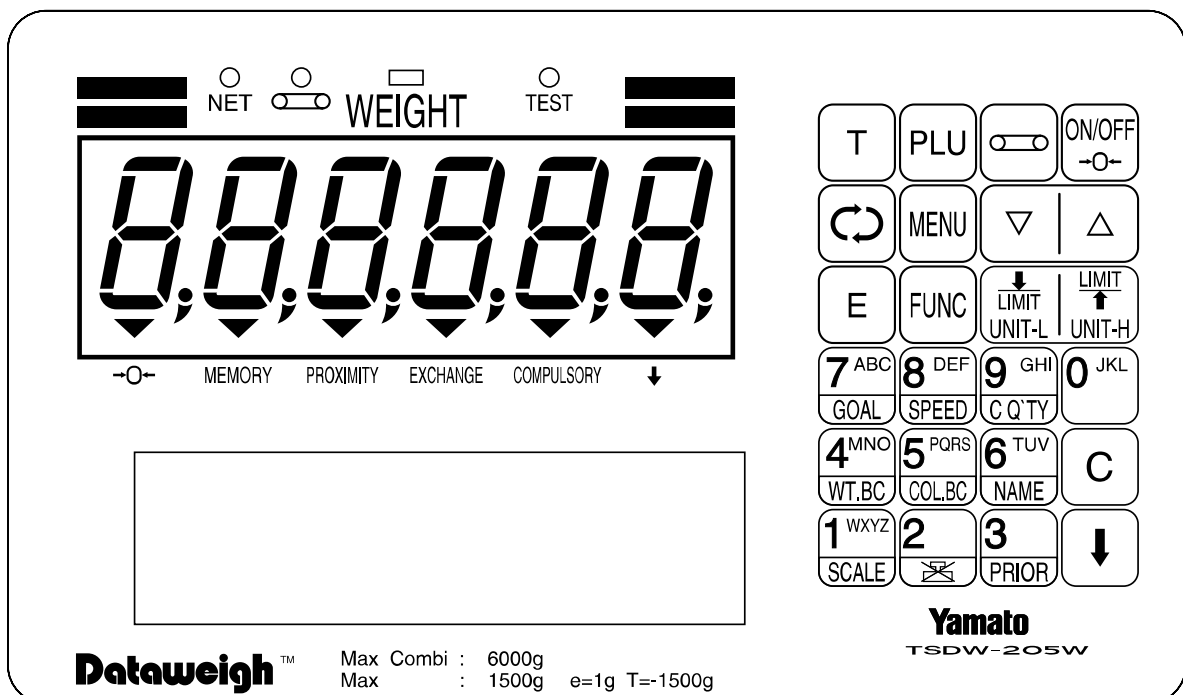









7. Display panel and key operation



8. Key operation

(1) Normal operation

Function when each key is pressed:









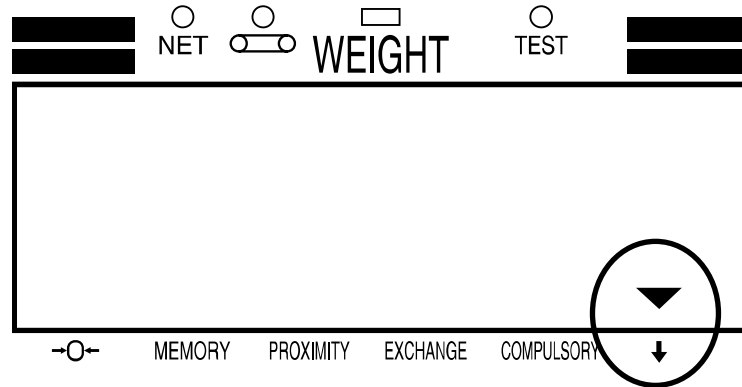



Key	Description of function
	Turn on power when the scale is off. Zero is reset when the scale is on. Turn off power by long press when the scale is on.
	Start combinatorial calculation and conveyor operation. Stop combinatorial calculation and conveyor work during operation.
	Recall or register the data
	Execute one-tough tare
	Move the cursor position or increase the number to be selected
	Move the cursor position or decrease the number to be selected
	Change the screens or the selected contents
	Recalculate for the next combination
	Change to the upper limit setting mode
	Change to the lower limit setting mode
	Change to the mode to set the functions for combination
	Determines the setting value entered.
Numeric key	Enter the designated number
	Cancel or zero the set value

(2) Shift key operation

When you press the  key, the shift sign turns on.

When you press a key in the above condition, the corresponding extended key function described below is enabled.



Key	Description of operation
	Switches to the screen to perform weight check for the weighing unit.
	Switches to the screen to set up the suspended scale.
	Switches to the screen to set up the prior scale.
	Switches to the screen to enter a speed of weighing conveyor.
	Switches to the screen to enter a speed of collating conveyor.
	Switches to the screen to enter an item name.
	Switches to the screen to enter a goal quantity of production.
	Switches to the screen to enter a target speed.
	Switches to the screen to set at quantity of the combination.
	Switches to the screen to enter an upper-limit value of unit weight.
	Switches to the screen to enter a lower-limit value of unit weight.
	Moves all the conveyors to discharge all products at combination mode.

9. About the display

(1) Main display

Lights up during conveyor operation.

Lights up during tare subtraction.

Lights up when the combination is formed

Lights up in scale check mode.

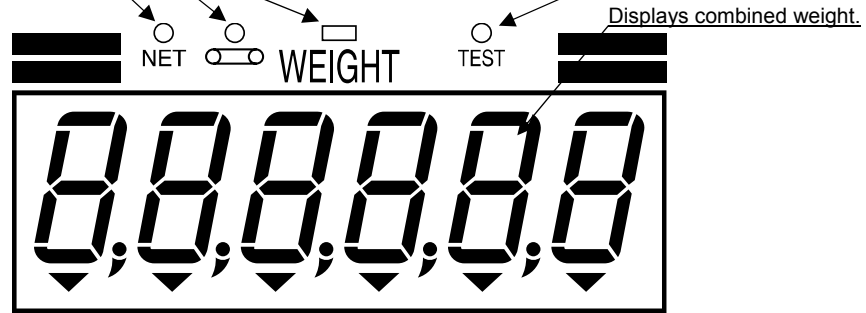

Lights up at the zero point.

Lights up when the memory card is recognized.

Lights up when the proximity combination is formed.

Lights up at exchange instruction.

Lights up when the compulsory combination is formed

Lights up when the Shift key is pressed.

(2) Sub-display: Full-dot LCD module

On the sub-display, eight data items can be displayed during a combination operation.

The entry of settings including the upper-limit and lower-limit value should be conducted on the sub-display.

During a combination operation, any screen can be selected from among the following four options.

Item No.	1	Name	Sample
ProQty	623 pcs	NoLeft	377 pcs
Ave. WT	110.7 g	Yield	0.7 g
Speed	15 ppm	T Left	26 min

Fig. 8-1. Example display of the 1st screen

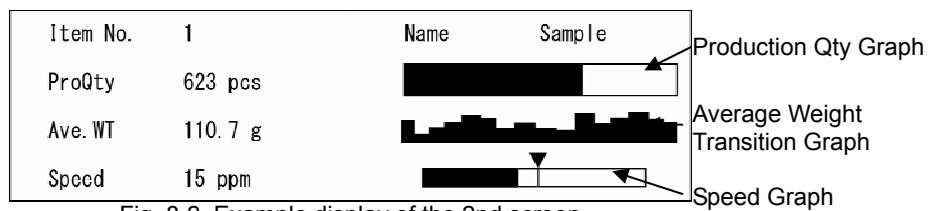

Fig. 8-2. Example display of the 2nd screen

Item No.	1	Name	Sample
Lo-LMT	110 g	Hi-LMT	120 g
Ave. WT	110.7 g	Speed	15 ppm
Goal	1000 pcs	ProQty	623 pcs

Fig. 8-3. Example display of the 3rd screen

Item No.	1	No. 1	53 g	No. 7	67 g
		No. 2	-OF-	No. 8	36 g
		No. 3	0 g	No. 9	74 g
		No. 4	0 g	No. 10	26 g
		No. 5	--LL	No. 11	0 g
		No. 6	39 g	No. 12	65 g

Fig. 8-4. Example display of the 4th screen

(3) Sub-display: Screen switching method

During a combination operation, each time **MENU** is pressed, the display is switched in order of 1st screen → 2nd screen → 3rd screen → 4th screen → 1st screen.

The display can be also switched by pressing .

Each time  is pressed, the display is switched in order of 1st screen → 2nd screen → 3rd screen → 4th screen → 1st screen.

Each time  is pressed, the display is switched in order of 1st screen → 4th screen → 3rd screen → 2nd screen → 1st screen.

(4) Sub-display: Displayed contents of 1st screen, 2nd screen and 3rd screen

The display screen is divided into eight blocks as shown in Fig. 8-5.

The items displayed in the two top lines are fixed both on the 1st screen and the 2nd screen.

① to ⑥ in the remaining 2nd, 3rd and 4th lines display the contents of Fig. 8-11 to Fig. 8-3 as the initial setting, but any items can be assigned to these blocks as you wish.

Setting of the displayed contents should be conducted with No. 036 to 053 of "36. User parameters table" in Page (54). For the method of setting user-defined parameters, refer to "35. How to set user parameters" in Page (52).

Item No. 1	Name	Sample
①		②
③		④
⑤		⑥

Fig. 8-5. Display screen assignment

[Fixed display]

Item No.Displays an item number called up. If not registered, "0" is displayed.

Name.....Displays an item name called up.

[User-settable display] (Blocks ① to ⑥)

Lo-LMTDisplays the lower-limit value of the current combined weight.

Hi-LMT.....Displays the upper-limit value of the current combined weight.

C. Q'ty.....Displays the setting of quantity combination.

Function settings display ...Displays the setting status of remains, proximity combination, exchange instruction, or priority combination.

Unit-L.....Displays the lower-limit value of the upper/lower limit discriminating function.

Unit-HDisplays the upper-limit value of the upper/lower limit discriminating function.

Ave.WT.....Displays the average of combined weight values. This is automatically updated each time the combination is confirmed.

TG SpeedThis is the target speed for combination operation. It is displayed in pieces per minute.

SpeedDisplays the speed of the current combination operation in pieces per minute. This value is automatically updated each time the combination is confirmed.

RemainTimeThe remain detecting function displays the time to detect as remains in minutes.

Date.....Displays the current date.

Time.....Displays the current time.

NoLeft.....Displays the remaining production number (the goal – the current production number). When the goal is not set, displays "goal is not set".

Yield.....Displays the balance between the average weight and the lower-limit value as yield

T LeftDisplay the time to be needed to reach the goal if the operation continues at the current speed.

Production Qty Graph.....The current status to the goal is shown in the graph.

Average Weight.....The movement of the latest average weights is shown in the graph.

Transition Graph

Speed GraphThe current speed to the target speed is shown in the graph.

(5) Production Qty graph

The current production to the goal is shown in the bar graph. It is easy to catch the current status from the graph as the bar graph extends until the production reaches to the goal.
When the goal is not set, it displays "goal is not set".

<<Example>> When the goal is 100 pcs

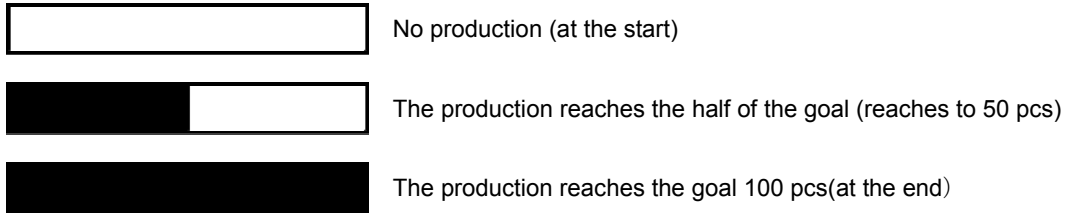

(6) Average Weight Transition Graph

The change in the latest average weight is shown in the bar graph and it is easy to catch the latest status of the yield from the graph.

The bottom edge stands for the lower-limit value and the top stands for the upper-limit value. The height of each bar graph shows the average weight of the latest 5 combinations. At each 5 combinations, the graph is updated. This graph can show 14 data at maximum.



(7) Speed Graph

The current speed to the target speed is shown in this graph and it is easy to catch the latest speed status from the graph. The point that the ▼ mark locates at the center of the graph is the target speed. The location at the left edge stands for 0 ppm and if the graph extend to the full range, the current speed is at double the target speed.

When the target speed is not set, it displays "target weight is not set".

<<Example>> When the target speed is 20 ppm

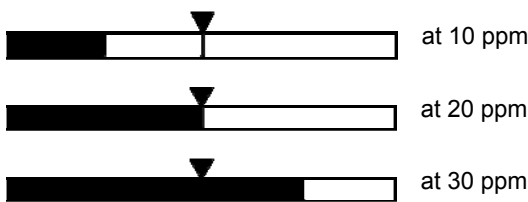

(8) Sub-display: Displayed contents of the 4th screen

As shown in Fig. 8-5, Item No. is displayed on the left side and the weight value of each weighing unit is displayed on the right side.

When a weighing unit is suspended or put into the error status, the "weight value" fields display as follows:

Display	Meaning
stop	The weighing unit is set to Suspend.
---HH	The weighing unit is in error status. For the details of the error, refer to "37. Error display" in Page (55).
----H	
---LL	
----L	
-OF-	
-UF-	

(9) LED lamp of the weighing section

The LED lamp of each weighing unit in the weighing section shows the state of the weighing unit such as when the combination is being formed.

The state to be indicated has been determined depending on the color of the lamp and whether the lamp is lit or blinking, as follows:

Check the state of weighing unit in the 4th screen, because it shows different states of scale even in the same state of lamp.

Operation of the lamp	State of the weighing unit
Lighting in yellow	In upper/lower limit discrimination error status. Upper/lower limit discriminating function...Page (35)
Blinking in yellow	Weighing items were not discharged from weighing conveyor properly. → Check if weighing items get lodged in weighing conveyor. Or Place items on weighing conveyor too quickly after discharge. → Remove items from the conveyor and place items again after lamp goes out. (Note) The error lamp can be set not to light in "37. User parameters table, #59". When setting #59 at 1 or 2, weighing combination can continue, but these settings are not recommended because defective packages due to discharge failure or weighing error may be produced. [Parameter #59] 0: The error lamp lights and TSDW shuts down until the error is released. (The products should be once removed from the head) 1: The error lamp lights but other heads continue to make a combination. (The lamp goes out when the products are once removed) 2: The error lamp does not light and all the heads continue to make a combination.
Lighting in green	Items remain. Remain detecting function...Page (40)
Blinking in green	The proximity combination is formed or exchange instruction is underway. Proximity combination, Exchange instruction underway...Page (38)
Lighting in yellow and green	The weighing unit is set to be suspended. At this time it is displayed as "stop" in the 3 rd screen. Setting of the suspended scale function...Page (43)
Blinking in yellow and green	The weighing unit is in error status. The details of the error can be confirmed by "30. Scale check function" in Page (44), or on the 3 rd screen.

10. Available functions

(1) Priority combination function

In the case of a packed product containing different items (e.g., a 500g packed product composed of one cut of fish tail (which must be included in every pack) and any other cuts), the priority combination function preferentially selects one weighing pan out of the weighing units designated as the prior scales and executes a combined calculation, involving this pan and other pans (other than the prior scales).

For setting of the function, refer to "22.Priority combination function" in Page (33).

(2) Proximity combination and auto recalculation functions

The proximity combination function works when there is no combination within the setting range though items to be weighed are put on all weighing units. The green lamp blinks when a proximity combination is formed.

For setting of the function, refer to "25.Proximity combination and auto recombination functions" in Page (38).

(3) Exchange instruction function

When items to be weighed are put on all weighing units and there is no combination within the setting range, this function indicates the weighing units which will form a combination at the highest probability by exchanging the items on them.

For setting of the function, refer to "26.Exchange instruction function" in Page (39).

(4) Quantity combination function

When the number of combined units is set in addition to setting of the target weight and upper-limit value, combinations, such as three pieces/ 200g, become possible. (Quantity = Number of weighing units)

For setting of the function, refer to "23.Quantity combination function" in Page (34).

(5) Remain Detection function

This function indicates the weighing units which has not participated in any combination for a long time.

The remain detecting function attempts to preferentially put into a combination the weighing units which has not participated in any combination for a certain period of time since items to be weighed were put on them. If any of those weighing units has still not participated in any combination for another period of time, the lamp of that weighing unit blinks in green to indicate the remains.

For setting of the function, refer to "27.Remain detecting function" in Page (40).

(6) Upper/lower limits discriminating function

This function puts an upper and lower limits on the weight of item to be weighed on a weighing unit.

If any item beyond the setting range is put on a weighing unit, its yellow lamp turns on.

For setting of the function, refer to "24.Upper/lower limit discriminating function" in Page (35).

(7) Target value setting function

This function sets a goal of production number and a target value of combination speed and compares them with the current actual values.

For setting of the function, refer to "28.Target value setting function" in Page (41).





(8) Scale check function

This function is capable of checking the respective 12 weighing units.

Since weight values are displayed, the weight of each weighing unit can be checked through this function.

For setting of the function, refer to "30.Scale check function" in Page (44).

11. How to turn on power

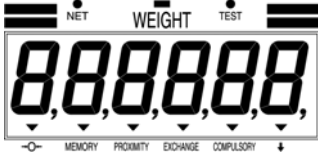
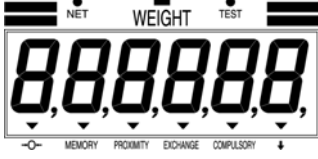
	Operating procedure	Displayed contents	Remarks
①	Check and confirm nothing remains on conveyors.		
②	Insert the power plug into the primary source.		
③	Insert the power plug of the latter process conveyor into the primary source.		Be sure to connect with the signal cable of the latter conveyor
④	Switch on the breaker.		Please refer the breaker's position to Page 9.
⑤	Wait for about 10 seconds.		There is some warming up time.
⑥	<p>[Power on]</p> <p>Press .</p> <p>Conduct conveyor check before starting operation.</p> <p>Press .</p> <p>Conveyor's motion check is started.</p>	 <p>Conveyor working check Start with [E] key.</p>	<p>Press  and then the conveyors are activated. Conduct this check before every operation start.</p> <p>Be sure the safety that nobody is touching the conveyor before starting the check.</p>
⑦	<p>[Conveyor working check]</p> <p>Motion check is conducted by 6 scales of row each by total twice.</p>	 <p>Conveyor working is being checked.</p>	Consult with the dealer when any of conveyors does not work.
⑧	<p>[Initialization of weigh head]</p> <p>When conveyor check is finished, initialization for scale is automatically started.</p>	<p>All the segments of fluorescent display flickers. At this time, the lamps of weighing heads turn on.</p>  <p>Weigh head is being initialized.</p>	Consult with the scale dealer when all segments are not lit.

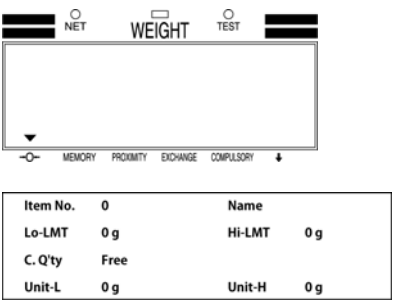
⑨	When flickering is stopped, the scale becomes ready. Start the operation after setting the conditions for combination.	 <table border="1" data-bbox="662 392 1054 504"> <tr> <td>Item No.</td> <td>0</td> <td>Name</td> <td></td> </tr> <tr> <td>Lo-LMT</td> <td>0 g</td> <td>Hi-LMT</td> <td>0 g</td> </tr> <tr> <td>C. Q'ty</td> <td>Free</td> <td></td> <td></td> </tr> <tr> <td>Unit-L</td> <td>0 g</td> <td>Unit-H</td> <td>0 g</td> </tr> </table>	Item No.	0	Name		Lo-LMT	0 g	Hi-LMT	0 g	C. Q'ty	Free			Unit-L	0 g	Unit-H	0 g	
Item No.	0	Name																	
Lo-LMT	0 g	Hi-LMT	0 g																
C. Q'ty	Free																		
Unit-L	0 g	Unit-H	0 g																

12. How to turn off power

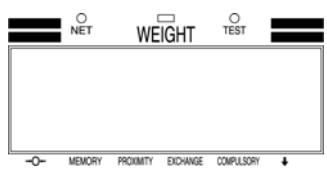
	Operating procedure	Displayed contents	Remarks
①	[Power off] Long-press 		This scale consumes stand-by power even if the display is turned off. Turn off the breaker and pull out the power plug when the scale is not operated for long time.

13. Emergency stop switch

If your cloth etc. was caught in conveyor belt or extraordinary noise happened during operation, press the emergency stop switch located in main body immediately. (See No. 12 of page 9)

Once the emergency stop switch is pressed, all power supply inside control panel is shut down and the conveyor does not work at all. But current has been applied inside the indicator and weighing part.

When securing the safety, pull up the emergency stop switch by rotating it in the direction of arrow. After

that, press  to resume operations.

	Operating procedure	Displayed contents	Remarks																
①	The emergency switch was pressed.	During the emergency stop The emergency button is being pressed.	When the emergency stop switch has been pressed at power on, the left display appears from the start.																
②	After confirming the safety, release the emergency stop.	During the emergency stop The emergency button was released. Restart with the [E] key.	Pull up the emergency stop switch by rotating it in the direction of arrow.																
③	Press  to resume operations.	<table border="1" data-bbox="678 1814 1085 1926"> <tr> <td>Item No.</td> <td>0</td> <td>Name</td> <td></td> </tr> <tr> <td>Lo-LMT</td> <td>110 g</td> <td>Hi-LMT</td> <td>0 g</td> </tr> <tr> <td>C. Q'ty</td> <td>Free</td> <td></td> <td></td> </tr> <tr> <td>Unit-L</td> <td>0 g</td> <td>Unit-H</td> <td>0 g</td> </tr> </table>	Item No.	0	Name		Lo-LMT	110 g	Hi-LMT	0 g	C. Q'ty	Free			Unit-L	0 g	Unit-H	0 g	
Item No.	0	Name																	
Lo-LMT	110 g	Hi-LMT	0 g																
C. Q'ty	Free																		
Unit-L	0 g	Unit-H	0 g																



[Note]

When the emergency stop switch is pressed during operations and machine resumes operations, it recalculates the combination. If any weighing items remain on collating conveyor at emergency stop, restart the operation after removing them.

14. Weight combination function

<<Example>> When setting the lower-limit value to 110 g and the upper-limit value to 120 g.

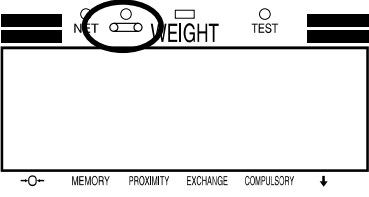

	Operating procedure	Displayed contents	Remarks
①	[Lower-limit value setting] Press .		The set value blinks.
②	Input and in this order.		The set value blinks.
③	Press .		
④	[Upper-limit value setting] Press .		The set value blinks.
⑤	Input and in this order.		The set value blinks.
⑥	Press .		
⑦	[Combination start] Press . Conveyor operation lamp lights up and combination calculation starts.		The combination calculation is not started unless conveyor operation lamp lights up.
⑧	Place weighing items on weighing conveyors. The combination calculation starts when weighing items are placed on more than 3 weighing conveyors.		The combination calculation does not start unless weighing items are on more than 3 weighing conveyors.
⑨	When a combination is formed, a weight value is displayed in the fluorescent display tube and conveyor starts to discharge.		Do not place items on weighing conveyor while conveyors are working.
⑩	Selected items are discharged.		Do not place items on weighing heads during discharge.

⑪	Repeat steps ⑦ to ⑨.		
⑬	[Combination stop] Press  when you want to stop combination and operation of conveyor. Conveyor operation light goes off and new combinations are not formed.		Press  again to restart conveyor operation.

If items are put on heads before the conveyor stops after discharge and weighing head is stabilize, combination work stops and LED lamp of weighing head turns on. In this case, remove the item and return it to the heads after blinking is finished. Or, operation can be resumed by pressing  on the indicator. In this case, the last combination is not counted into the production quantity.

15. All discharge function

When discharging all the weighing items on weighing conveyors at end of work or change of item, all discharge function enables getting all the weighing conveyors to work to discharge all weighing items.



	Operating procedure	Displayed contents	Remarks
①	After pressing  key, press  key. When discharges from all weighing units have completed, the Zero sign lights up.		

16. Operation of scale functions

(1) How to zero-reset



Zero reset should be performed when the zero point of a weighing unit was displaced because of the adhesion of a weighed item to the unit or cleaning.

Zero reset in combination mode is activated for all weighing units simultaneously.

	Operating procedure	Displayed contents	Remarks
①	Press  after confirming that nothing are placed on weighing conveyors. When all weighing units are reset to zero successfully, the Zero sign lights up.		

(2) How to zero-reset for individual scale

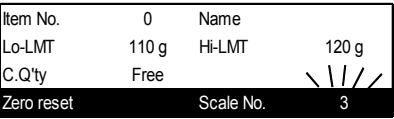
Zero reset can be performed for a particular scale. No need to remove items from all weighing heads.





	Operating procedure	Displayed contents	Remarks
①	Press 		The set value blinks
②	Press 		Zero-reset is completed

(3) How to conduct tare subtraction



This function is convenient when weighing an item placed in a container etc.

The tare subtraction in combination mode is activated for all weighing units simultaneously.

When you want to perform the tare subtraction only for a specific weighing unit, refer to "Scale check function" in Page (44).

	Operating procedure	Displayed contents	Remarks
①	Put only one container on the weighing unit.		Tare subtraction is performed only for scale on which tare is placed.
②	Press  when the weighing unit is stabilized.		When tare subtraction is completed, the NET lamp and Zero sign light up.
③	[Combination start] Put items to be weighed on the weighing units, and start combined weighing.		



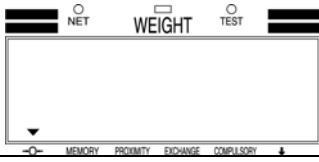

(4) How to cancel tare subtraction

	Operating procedure	Displayed contents	Remarks
①	Remove the container from the weighing unit.		
②	Press 		The Tare sign is go off and the Zero signal lights up.

(5) How to clear the set value

This is the operation to clear the current set value. The same operation applies to other setting items as well.

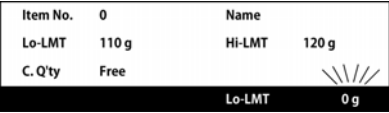

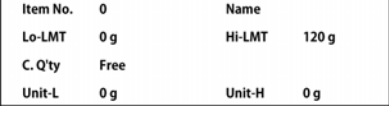

<<Example>> When clearing the lower-limit value (resetting to zero)

	Operating procedure	Displayed contents	Remarks
①	Press 		The set value blinks.
②	[Lower-limit value clearing] Press 		The set value blinks.
③	Press 		

(6) Stopping the input of set values

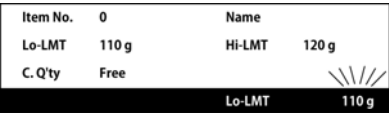
This is the operation to stop the input of the incorrect set values and to reset to the original set values during setting. The same operation applies to other setting items as well.

<<Example>> When stopping the input of the lower-limit value

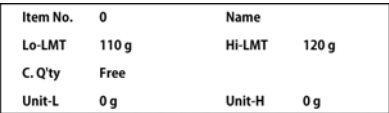
	Operating procedure	Displayed contents	Remarks
①	Press 		The set value blinks.
②	Input  and  by mistake.		The set value blinks.
③	[Stop of lower-limit value input] Press 		Input is stopped, and the lower-limit value before input, 110 g, is called back.







17. Setting of the conveyor speed

As for the weighing conveyors on weighing units and the collating conveyors to carry the combined weighing products, the speed of each conveyor can be set by weighing products.

(1) Setting the weighing conveyor speed

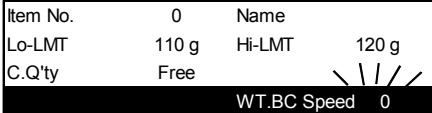
The weighing conveyor speed can be set on a scale of 0 to 4. (5 levels)

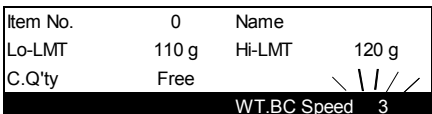
e.g.) Setting the weighing conveyor speed at 5.

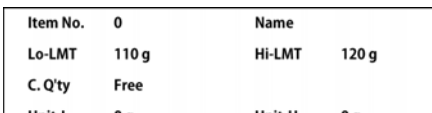
	Operation	Display	Remarks
①	[Weighing conveyor speed] After press the  key, press the  key.		The setting value is blinking.
②	Press the  key to enter the setting value.		The setting value is blinking.
③	Press the  key to save the value.		The speed level of 5 has been set.

Note:







After the weighing conveyor speed is set, the speed is changed by a controller. If the difference between the previous setting value and the new setting value is big, it takes some time to change the speed.

When you change the speed, wait for the corresponding time and conduct the test run before operation to confirm the speed. It takes 30 seconds to change 1 level, so if you change 5 levels, it takes about 2 minutes 30 seconds.

(2) Setting the collating conveyor

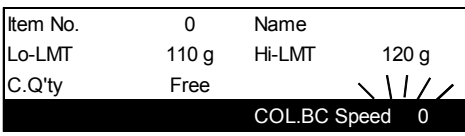
The collating conveyor speed can be set on a scale of 0 to 4. (5 levels)

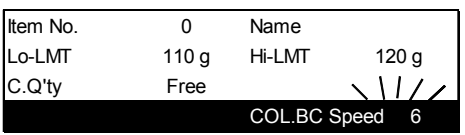
e.g.) Setting the collating conveyor speed at 5.

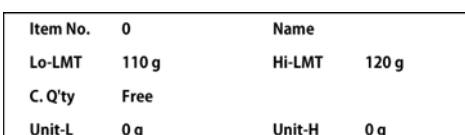
	Operation	Display	Remarks
①	[Collating conveyor speed] After press the  key, press the  key.		The setting value is blinking.
②	Press the  key to enter the setting value.		The setting value is blinking.
③	Press the  key to save the value.		The speed level of 6 has been set.

18. Setting of discharging mode

The TSDW-205(W) has 2 selectable discharging modes as below.
Select the suitable mode depending on the weighing items and its latter process.

[Functional Options]

Simultaneous dump....Discharge combined items at the same time. [Default setting]









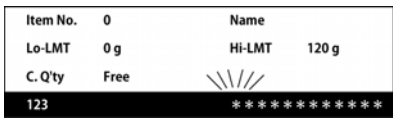

Grouping dump.....Discharge combined items as one group.

<<Example>> Change the setting from “Dump simultaneous” to “Dump together”

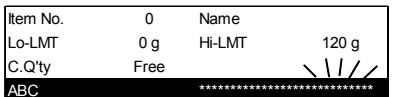
	Operation	Display	Remarks																
①	Press the FUNC key to go into combination function setting mode.	<table border="1"> <tr> <td>Item No.</td> <td>0</td> <td>Name</td> <td></td> </tr> <tr> <td>Lo-LMT</td> <td>110 g</td> <td>Hi-LMT</td> <td>120 g</td> </tr> <tr> <td>C.Q'ty</td> <td>Free</td> <td></td> <td></td> </tr> <tr> <td>Prox.&Exch.</td> <td></td> <td></td> <td>OFF</td> </tr> </table>	Item No.	0	Name		Lo-LMT	110 g	Hi-LMT	120 g	C.Q'ty	Free			Prox.&Exch.			OFF	
Item No.	0	Name																	
Lo-LMT	110 g	Hi-LMT	120 g																
C.Q'ty	Free																		
Prox.&Exch.			OFF																
②	Press the MENU key 4 times, and then “Dump mode” is displayed.	<table border="1"> <tr> <td>Item No.</td> <td>0</td> <td>Name</td> <td></td> </tr> <tr> <td>Lo-LMT</td> <td>110 g</td> <td>Hi-LMT</td> <td>120 g</td> </tr> <tr> <td>C.Q'ty</td> <td>Free</td> <td></td> <td></td> </tr> <tr> <td>Dump mode:</td> <td></td> <td></td> <td>Simultaneous dump</td> </tr> </table>	Item No.	0	Name		Lo-LMT	110 g	Hi-LMT	120 g	C.Q'ty	Free			Dump mode:			Simultaneous dump	Default setting
Item No.	0	Name																	
Lo-LMT	110 g	Hi-LMT	120 g																
C.Q'ty	Free																		
Dump mode:			Simultaneous dump																
③	Press ▲ once to display grouping mode. And, press ▼ to move the setting reversely.	<table border="1"> <tr> <td>Item No.</td> <td>0</td> <td>Name</td> <td></td> </tr> <tr> <td>Lo-LMT</td> <td>110 g</td> <td>Hi-LMT</td> <td>120 g</td> </tr> <tr> <td>C.Q'ty</td> <td>Free</td> <td></td> <td></td> </tr> <tr> <td>Dump mode:</td> <td></td> <td></td> <td>Grouping dump</td> </tr> </table>	Item No.	0	Name		Lo-LMT	110 g	Hi-LMT	120 g	C.Q'ty	Free			Dump mode:			Grouping dump	
Item No.	0	Name																	
Lo-LMT	110 g	Hi-LMT	120 g																
C.Q'ty	Free																		
Dump mode:			Grouping dump																
④	Press the E key to save the value.	<table border="1"> <tr> <td>Item No.</td> <td>0</td> <td>Name</td> <td></td> </tr> <tr> <td>Lo-LMT</td> <td>110 g</td> <td>Hi-LMT</td> <td>120 g</td> </tr> <tr> <td>C. Q'ty</td> <td>Free</td> <td></td> <td></td> </tr> <tr> <td>Unit-L</td> <td>0 g</td> <td>Unit-H</td> <td>0 g</td> </tr> </table>	Item No.	0	Name		Lo-LMT	110 g	Hi-LMT	120 g	C. Q'ty	Free			Unit-L	0 g	Unit-H	0 g	
Item No.	0	Name																	
Lo-LMT	110 g	Hi-LMT	120 g																
C. Q'ty	Free																		
Unit-L	0 g	Unit-H	0 g																

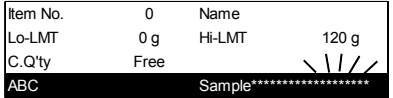
19. How to input item name

<<Example>> When inputting "Sample" in the item name field

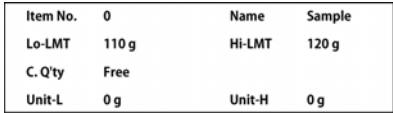
	Operating procedure	Displayed contents	Remarks
①	Press  , and then press  .		The item names are input on the sub-display. The setting digit blinks.
②	[Input character switching] Press  twice.	 ↑ Input character mode	 : Input character switching Numeric mode (123) ↓ Alphabetic mode (ABC) ↓ Numeric mode (123) The mode switches in the above order. Parenthesized characters are displayed at the left end.
③	[Character input] Enter characters in reference to the character assignment table. «Example» When entering "S" Press  4 times.		Pressing  deletes one character. Pressing   moves the character input position.
④	Press  .		The combination mode is called back.

Character assignment to keys

Key	Numeric mode	Alphabetic mode
Switch	To Alphabetic mode	To Numeric mode
0	0	J K L j k l 0
1	1	W X Y Z w x y z 1
2	2	2
3	3	3
4	4	M N O m n o 4
5	5	P Q R S p q r s 5
6	6	T U V t u v 6
7	7	A B C a b c 7
8	8	D E F d e f 8
9	9	G H I g h i 9
Tare	. - ? ! (Space)	. - ? ! (Space)

20. How to register items

The TSDW-205(W) can store upper/lower limit, conveyor speed, prior scale setting, quantity combination setting, individual upper/lower weight setting, proximity combination, remain detection, target quantity, target speed and item name for each recall number.

There are 100 Recall numbers from 1 to 100, allowing data of 100 items to be stored.

Because this data is stored in the internal memory, it is not erased if the scale is switched off.







Registering the data that is frequently used every day makes settings prior to the operation easier, and improves working efficiency remarkably.

<<Example>> When registering the set contents to Recall No. 70

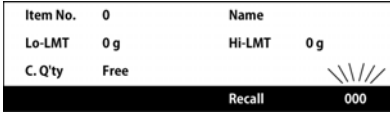
	Operating procedure	Displayed contents	Remarks																																
①	Previously set the data that you want to register. Items which are not set are not registered.	<table border="1"> <tr><td>Item No.</td><td>0</td><td>Name</td><td>Sample</td></tr> <tr><td>Lo-LMT</td><td>110 g</td><td>Hi-LMT</td><td>120 g</td></tr> <tr><td>C. Q'ty</td><td>3 ~ 5 pcs</td><td>Prior · Prox · Remn</td><td></td></tr> <tr><td>Unit-H</td><td>40 g</td><td>Unit-H</td><td>100 g</td></tr> </table>	Item No.	0	Name	Sample	Lo-LMT	110 g	Hi-LMT	120 g	C. Q'ty	3 ~ 5 pcs	Prior · Prox · Remn		Unit-H	40 g	Unit-H	100 g																	
Item No.	0	Name	Sample																																
Lo-LMT	110 g	Hi-LMT	120 g																																
C. Q'ty	3 ~ 5 pcs	Prior · Prox · Remn																																	
Unit-H	40 g	Unit-H	100 g																																
②	Continues to press PLU until "Registered" is displayed. (During setting, the display is blinking.)	<table border="1"> <tr><td>Item No.</td><td>0</td><td>Name</td><td>Sample</td></tr> <tr><td>Lo-LMT</td><td>110 g</td><td>Hi-LMT</td><td>120 g</td></tr> <tr><td>C. Q'ty</td><td>3 ~ 5 pcs</td><td>Prior · Prox · Remn</td><td></td></tr> <tr><td colspan="3"></td><td>Recall 000</td></tr> </table> <p style="text-align: center;">↓</p> <table border="1"> <tr><td>Item No.</td><td>0</td><td>Name</td><td>Sample</td></tr> <tr><td>Lo-LMT</td><td>110 g</td><td>Hi-LMT</td><td>120 g</td></tr> <tr><td>C. Q'ty</td><td>3 ~ 5 pcs</td><td>Prior · Prox · Remn</td><td></td></tr> <tr><td colspan="3"></td><td>Register 000</td></tr> </table>	Item No.	0	Name	Sample	Lo-LMT	110 g	Hi-LMT	120 g	C. Q'ty	3 ~ 5 pcs	Prior · Prox · Remn					Recall 000	Item No.	0	Name	Sample	Lo-LMT	110 g	Hi-LMT	120 g	C. Q'ty	3 ~ 5 pcs	Prior · Prox · Remn					Register 000	
Item No.	0	Name	Sample																																
Lo-LMT	110 g	Hi-LMT	120 g																																
C. Q'ty	3 ~ 5 pcs	Prior · Prox · Remn																																	
			Recall 000																																
Item No.	0	Name	Sample																																
Lo-LMT	110 g	Hi-LMT	120 g																																
C. Q'ty	3 ~ 5 pcs	Prior · Prox · Remn																																	
			Register 000																																
③	[Recall number input] Input 7 and 0 in this order.	<table border="1"> <tr><td>Item No.</td><td>0</td><td>Name</td><td>Sample</td></tr> <tr><td>Lo-LMT</td><td>110 g</td><td>Hi-LMT</td><td>120 g</td></tr> <tr><td>C. Q'ty</td><td>3 ~ 5 pcs</td><td>Prior · Prox · Remn</td><td></td></tr> <tr><td colspan="3"></td><td>Register 070</td></tr> </table>	Item No.	0	Name	Sample	Lo-LMT	110 g	Hi-LMT	120 g	C. Q'ty	3 ~ 5 pcs	Prior · Prox · Remn					Register 070	When you want to cancel registration, press C , and go to ④ after confirming that the Recall number "000" is displayed. At this time, the error buzzer sounds and registration is cancelled.																
Item No.	0	Name	Sample																																
Lo-LMT	110 g	Hi-LMT	120 g																																
C. Q'ty	3 ~ 5 pcs	Prior · Prox · Remn																																	
			Register 070																																
④	Press E .	<table border="1"> <tr><td>Item No.</td><td>70</td><td>Name</td><td>Sample</td></tr> <tr><td>Lo-LMT</td><td>110 g</td><td>Hi-LMT</td><td>120 g</td></tr> <tr><td>C. Q'ty</td><td>3 ~ 5 pcs</td><td>Prior · Prox · Remn</td><td></td></tr> <tr><td>Unit-H</td><td>40 g</td><td>Unit-H</td><td>100 g</td></tr> </table>	Item No.	70	Name	Sample	Lo-LMT	110 g	Hi-LMT	120 g	C. Q'ty	3 ~ 5 pcs	Prior · Prox · Remn		Unit-H	40 g	Unit-H	100 g	The data has been registered to Item No. 70.																
Item No.	70	Name	Sample																																
Lo-LMT	110 g	Hi-LMT	120 g																																
C. Q'ty	3 ~ 5 pcs	Prior · Prox · Remn																																	
Unit-H	40 g	Unit-H	100 g																																

21. How to call up item data

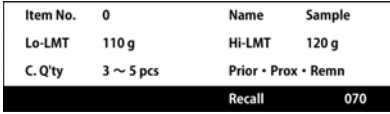
<<Example>> When calling up the item data of item No. 70 registered as described in the previous page

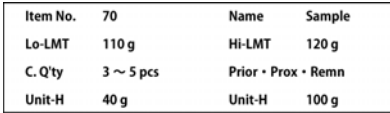
	Operating procedure	Displayed contents	Remarks
①	Press  .		The set value blinks.
②	<p>[Recall number input] Input  and  in this order. It is also possible to select the Recall No. by pushing  .</p> <p>In this case, only the number under which data is registered is displayed.</p>		<p>The setting value of the item is displayed on upper 3 lines.</p> <p>When you want to cancel the calling up, press .</p>
③	Press  .		The registered data has been called up.

22. How to clear item data

Call up Item No. 0, clear all the set values to "0", and then register data for any item No. and the data regarding the number is cleared.

23. Priority combination function











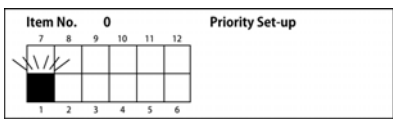

In the case of a packed product containing different items (e.g., a 500g packed product composed of one cut of fish tail (which must be included in each pack) and any other cuts), the priority combination function preferentially selects one weighing unit designated as the prior scale and executes a combined calculation, involving this unit and any other units (other than the prior scales).

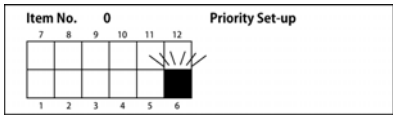
The combination calculation is not performed unless an item to be weighed is put on the prior scales.

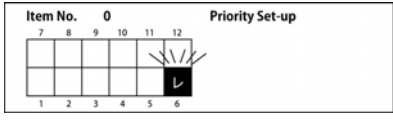
Though multiple weighing units are designated as the prior scales, one combination is performed by using only one prior scale and other weighing units.

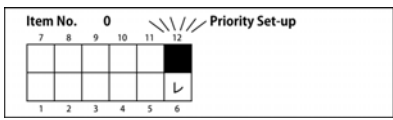
Note that no combination can be formed if all weighing units are designated as the prior scales.

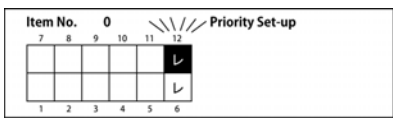
<<Example>> When designating No. 6 and No. 12 weighing units as the prior scale

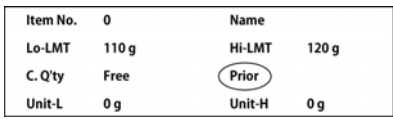





	Operating procedure	Displayed contents	Remarks
①	Press  , and then press 		The area corresponding to the currently selected weighing unit blinks.
②	[Weighing unit selection] Press  5 times to select No. 6 weighing unit. When  is pressed, the numeric value shifts in the reverse direction.		The area corresponding to the currently selected weighing unit blinks.
③	[Prior scale setting] When  is pressed, No. 6 is designated as a prior scale and the display changes to the ticked mark. When  is pressed again, the prior scale is cancelled.		The area corresponding to the currently selected weighing unit blinks.
④	Continue to make setting of No. 12 weighing unit. Press  6 times to select No. 12 weighing unit.		The area corresponding to the currently selected weighing unit blinks.
⑤	When  is pressed, No. 12 is designated as a prior scale and the display changes to the ticked mark.		The area corresponding to the currently selected weighing unit blinks.
⑥	Press  . Start the priority combination.		The setting is reflected in the Function/Condition field.

It is also possible to set a prior scale on the Scale Status screen.
For the setting method, refer to "Scale check function" in Page (44).



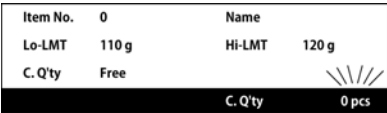



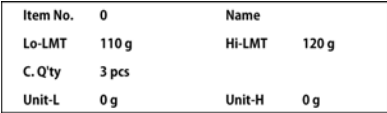

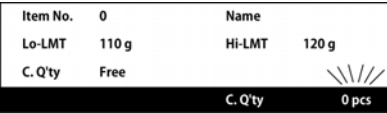

24. Quantity combination function

If the number of combined units (Quantity = Number of weighing units) is set in addition to setting of the lower-limit and upper-limit values, combinations, such as three pieces/ 110g, become possible. A range can be defined instead of a number of combined units, so if it is assumed that the range is between three and five, a combination can be found with three or four or five units involved.

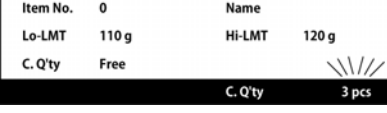
<<Example 1>> When combining items on three weighing items into a 110 to120g product

	Operating procedure	Displayed contents	Remarks
①	[Quantity setting] Press  , and then press 		The set value blinks.
②	Enter 		The set value blinks.
③	Press 		

<<Example 2>> When combining items on three to five weighing items into a 110 to130g product

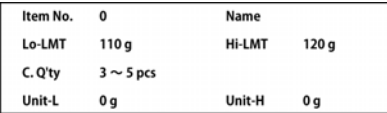
	Operating procedure	Displayed contents	Remarks
①	[Quantity setting] Press  , and then press 		The set value blinks.
②	Enter 		The set value blinks.
③	[Upper-limit quantity setting] Press 		The set value blinks.
④	Enter 		The set value blinks.
⑤	Press 		

25. Upper/lower limit discriminating function

This function puts an upper-limit and a lower-limit on the weight value of each item which is to be placed on a weighing unit.

It is also possible to set only either of an upper-limit or lower-limit value.

When an item that exceeds the setting range is put on, the function indicates an Upper/lower limit error, by blinking the LED lamp in yellow. In such a case, the function also issues a warning with a buzzer. (The buzzer ON/OFF status can be changed by the user-defined parameter.)

When the item is removed and exchanged with a new item and the weight of the new item falls within the upper and/or lower limit, the error stops.

Even if any weighing unit for which an error has occurred is included, the combination operation continues by involving other weighing units.













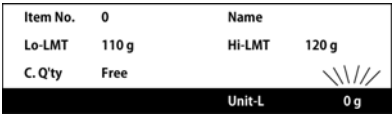

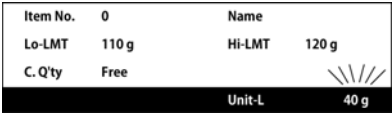
When an external scale is used, the same upper/lower limit setting applies to it as for a TSDW weighing unit.

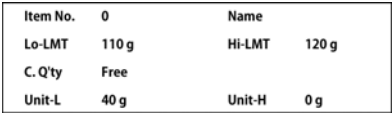
(1) Setting of the upper/lower limit discriminating function

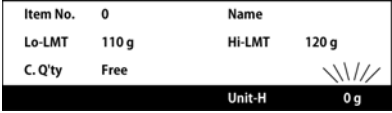
If the upper/lower limit discriminating function is set for an item, the setting applies whenever the item is selected.

- Unit-H value : To be set when the upper-limit value for the weight per unit is specified.
- Unit-L value : To be set when the lower-limit value for the weight per unit is specified.
- However, when 0 g is specified, the function does not work.

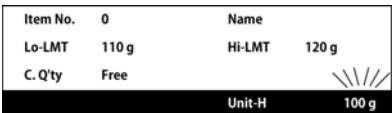
<<Example>> When setting the Unit-L value to 40 g and the Unit-H value to 100 g

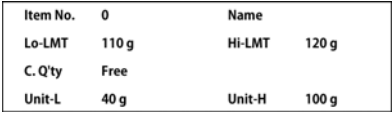
	Operating procedure	Displayed contents	Remarks
①	<p>[Unit-L value setting] Press , and then press </p>		The set value blinks.
②	<p>Input  and  in this order.</p>		The set value blinks.
③	<p>Press </p>		
④	<p>[Unit-H value setting] Press , and then press </p>		The set value blinks.
⑤	<p>Input ,  and  in this order.</p>		The set value blinks.
⑥	<p>Press </p>		

Note: It is also possible to input either upper or lower limit only.

(2) Setting of the prior scale & upper/lower limit discriminating function

When the unit weight's upper/lower limit discriminating function and prior scale function are used together, it is possible to select whether to enable or disable the unit weight's upper/lower limit error discrimination for the prior scale.

[Functional options]

OFFThe unit weight's upper/lower limit error discrimination for the prior scale is disabled.[Default]

ONThe unit weight's upper/lower limit error discrimination for the prior scale is enabled.

<<Example>> When enabling the unit weight's upper/lower limit error discrimination for the prior scale

	Operating procedure	Displayed contents	Remarks																
①	Press FUNC . The combination function setting mode is established.	<table border="1"> <tr> <td>Item No.</td> <td>0</td> <td>Name</td> <td></td> </tr> <tr> <td>Lo-LMT</td> <td>110 g</td> <td>Hi-LMT</td> <td>120 g</td> </tr> <tr> <td>C. Q'ty</td> <td>Free</td> <td></td> <td></td> </tr> <tr> <td>Prox.&Exch.</td> <td></td> <td></td> <td>OFF</td> </tr> </table>	Item No.	0	Name		Lo-LMT	110 g	Hi-LMT	120 g	C. Q'ty	Free			Prox.&Exch.			OFF	
Item No.	0	Name																	
Lo-LMT	110 g	Hi-LMT	120 g																
C. Q'ty	Free																		
Prox.&Exch.			OFF																
②	[Setting item switching] Press MENU twice. "Hi&Lo Limit/Prior Scale" is displayed.	<table border="1"> <tr> <td>Item No.</td> <td>0</td> <td>Name</td> <td></td> </tr> <tr> <td>Lo-LMT</td> <td>110 g</td> <td>Hi-LMT</td> <td>120 g</td> </tr> <tr> <td>C. Q'ty</td> <td>Free</td> <td>Prior</td> <td></td> </tr> <tr> <td>Hi&Lo Limit/Prior Scale</td> <td></td> <td></td> <td>OFF</td> </tr> </table>	Item No.	0	Name		Lo-LMT	110 g	Hi-LMT	120 g	C. Q'ty	Free	Prior		Hi&Lo Limit/Prior Scale			OFF	
Item No.	0	Name																	
Lo-LMT	110 g	Hi-LMT	120 g																
C. Q'ty	Free	Prior																	
Hi&Lo Limit/Prior Scale			OFF																
③	[Set contents selection] Press △ once to select ON. When ▽ is pressed, the set contents shift in the reverse direction.	<table border="1"> <tr> <td>Item No.</td> <td>0</td> <td>Name</td> <td></td> </tr> <tr> <td>Lo-LMT</td> <td>110 g</td> <td>Hi-LMT</td> <td>120 g</td> </tr> <tr> <td>C. Q'ty</td> <td>Free</td> <td>Prior</td> <td></td> </tr> <tr> <td>Hi&Lo Limit/Prior Scale</td> <td></td> <td></td> <td>ON</td> </tr> </table>	Item No.	0	Name		Lo-LMT	110 g	Hi-LMT	120 g	C. Q'ty	Free	Prior		Hi&Lo Limit/Prior Scale			ON	
Item No.	0	Name																	
Lo-LMT	110 g	Hi-LMT	120 g																
C. Q'ty	Free	Prior																	
Hi&Lo Limit/Prior Scale			ON																
④	Press E . The prior scale & upper/lower limit discriminating function is enabled.	<table border="1"> <tr> <td>Item No.</td> <td>0</td> <td>Name</td> <td></td> </tr> <tr> <td>Lo-LMT</td> <td>110 g</td> <td>Hi-LMT</td> <td>120 g</td> </tr> <tr> <td>C. Q'ty</td> <td>Free</td> <td>Prior</td> <td></td> </tr> <tr> <td>Unit-L</td> <td>40 g</td> <td>Unit-H</td> <td>100 g</td> </tr> </table>	Item No.	0	Name		Lo-LMT	110 g	Hi-LMT	120 g	C. Q'ty	Free	Prior		Unit-L	40 g	Unit-H	100 g	
Item No.	0	Name																	
Lo-LMT	110 g	Hi-LMT	120 g																
C. Q'ty	Free	Prior																	
Unit-L	40 g	Unit-H	100 g																

26. Proximity combination and auto recombination functions

When items to be weighed are put on all weighing units and there is no combination within the setting range, the proximity combination function displays a combination value which is the nearest to the upper-limit or lower-limit value.

When the combined value is outside the ranges of the preset target weight and upper-limit value, the proximity combination function blinks the green lamp to indicate that a proximity combination has been formed.

When some items to be weighed are exchanged, recalculation is made automatically and, if there is any combination that falls within the setting range, the lamp changes blinking to lighting up to confirm the combination.

Target weight: 100g

Upper-limit value: This value was set to 102 g, but no combination falls within the setting range but there is the nearest combination value of 105 g. Then, the combination corresponding to 105 g is indicated as the proximity combination.

[Functional options]

OFF Performs no operation when no combination is formed. [Default setting]

Proximity(+)..... Selects the combination that is equal to or higher than the upper-limit value and nearest to the target weight.

Proximity(-)..... Selects the combination that is equal to or lower than the lower-limit value and nearest to the target weight.

Proximity(+/-) ... Selects one of the above two options, whichever is the nearest.

Exchange Indicates a weighing unit which requires item exchange. (Refer to Page 39.)

<<Example>> When setting the proximity combination (that is equal to or higher than the upper-limit value and the nearest to the target weight)

	Operating procedure	Displayed contents	Remarks																
①	Press FUNC . The combination function setting mode is established.	<table border="1"> <tr> <td>Item No.</td> <td>0</td> <td>Name</td> <td></td> </tr> <tr> <td>Lo-LMT</td> <td>110 g</td> <td>Hi-LMT</td> <td>120 g</td> </tr> <tr> <td>C. Q'ty</td> <td>Free</td> <td></td> <td></td> </tr> <tr> <td colspan="2">Remain Setting</td> <td colspan="2">OFF</td> </tr> </table>	Item No.	0	Name		Lo-LMT	110 g	Hi-LMT	120 g	C. Q'ty	Free			Remain Setting		OFF		
Item No.	0	Name																	
Lo-LMT	110 g	Hi-LMT	120 g																
C. Q'ty	Free																		
Remain Setting		OFF																	
②	[Setting item switching] Press MENU once. "Prox. & Exch." is displayed.	<table border="1"> <tr> <td>Item No.</td> <td>0</td> <td>Name</td> <td></td> </tr> <tr> <td>Lo-LMT</td> <td>110 g</td> <td>Hi-LMT</td> <td>120 g</td> </tr> <tr> <td>C. Q'ty</td> <td>Free</td> <td></td> <td></td> </tr> <tr> <td colspan="2">Prox. & Exch.</td> <td colspan="2">OFF</td> </tr> </table>	Item No.	0	Name		Lo-LMT	110 g	Hi-LMT	120 g	C. Q'ty	Free			Prox. & Exch.		OFF		
Item No.	0	Name																	
Lo-LMT	110 g	Hi-LMT	120 g																
C. Q'ty	Free																		
Prox. & Exch.		OFF																	
③	[Set contents selection] Press △ once to select Proximity (+). When ▽ is pressed, the set contents shift in the reverse direction.	<table border="1"> <tr> <td>Item No.</td> <td>0</td> <td>Name</td> <td></td> </tr> <tr> <td>Lo-LMT</td> <td>110 g</td> <td>Hi-LMT</td> <td>120 g</td> </tr> <tr> <td>C. Q'ty</td> <td>Free</td> <td></td> <td></td> </tr> <tr> <td colspan="2">Prox. & Exch.</td> <td colspan="2">Accept over(+)</td> </tr> </table>	Item No.	0	Name		Lo-LMT	110 g	Hi-LMT	120 g	C. Q'ty	Free			Prox. & Exch.		Accept over(+)		
Item No.	0	Name																	
Lo-LMT	110 g	Hi-LMT	120 g																
C. Q'ty	Free																		
Prox. & Exch.		Accept over(+)																	
④	Press E . The proximity combination is enabled.	<table border="1"> <tr> <td>Item No.</td> <td>0</td> <td>Name</td> <td></td> </tr> <tr> <td>Lo-LMT</td> <td>110 g</td> <td>Hi-LMT</td> <td>120 g</td> </tr> <tr> <td>C. Q'ty</td> <td>Free</td> <td>Prox</td> <td></td> </tr> <tr> <td>Unit-L</td> <td>0 g</td> <td>Unit-H</td> <td>0 g</td> </tr> </table>	Item No.	0	Name		Lo-LMT	110 g	Hi-LMT	120 g	C. Q'ty	Free	Prox		Unit-L	0 g	Unit-H	0 g	The setting is reflected in the Function/Condition field.
Item No.	0	Name																	
Lo-LMT	110 g	Hi-LMT	120 g																
C. Q'ty	Free	Prox																	
Unit-L	0 g	Unit-H	0 g																

[Note]

Proximity combination function does not work unless items to be weighed are put on all weighing units.

27. Exchange instruction function

When items to be weighed are put on all weighing units and there is no combination within the setting range, this function indicates the weighing units which will form a combination at the highest probability by exchanging items on them.

When the exchange instruction function is used, a blinking green lamp indicates weighing unit items on which should be exchanged.

In that case, exchange all the weighed items on the weighing units for which lamps are blinking and the green lamp stops blinking. If there is a combination that falls within the setting range, the green lamp lights up to confirm the combination.

The number of items exchangeable at one time can be set by user-defined parameters.

[Functional options]

OFF Performs no operation when no combination is formed. [Default setting]

Proximity(+)..... Selects a combination value that is equal to or higher than the upper-limit value and the nearest to the target weight. (Refer to Page 38)

Proximity(-)..... Selects a combination value that is equal to or lower than the lower-limit value and the nearest to the target weight. (Refer to Page 38)

Proximity(+ · -)... Selects one of the above two options, whichever is the nearest. (Refer to Page 38)

Exchange Indicates a weighing unit which requires item exchange.

<<Example>> When setting the exchange instruction

	Operating procedure	Displayed contents	Remarks																
①	Press FUNC . The combination function setting mode is established.	<table border="1"> <tr> <td>Item No.</td> <td>0</td> <td>Name</td> <td></td> </tr> <tr> <td>Lo-LMT</td> <td>110 g</td> <td>HI-LMT</td> <td>120 g</td> </tr> <tr> <td>C. Q'ty</td> <td>Free</td> <td></td> <td></td> </tr> <tr> <td colspan="2">Remain Setting</td> <td colspan="2">OFF</td> </tr> </table>	Item No.	0	Name		Lo-LMT	110 g	HI-LMT	120 g	C. Q'ty	Free			Remain Setting		OFF		
Item No.	0	Name																	
Lo-LMT	110 g	HI-LMT	120 g																
C. Q'ty	Free																		
Remain Setting		OFF																	
②	[Setting item switching] Press MENU once. "Prox. & Exch." is displayed.	<table border="1"> <tr> <td>Item No.</td> <td>0</td> <td>Name</td> <td></td> </tr> <tr> <td>Lo-LMT</td> <td>110 g</td> <td>HI-LMT</td> <td>120 g</td> </tr> <tr> <td>C. Q'ty</td> <td>Free</td> <td></td> <td></td> </tr> <tr> <td colspan="2">Prox. & Exch.</td> <td colspan="2">OFF</td> </tr> </table>	Item No.	0	Name		Lo-LMT	110 g	HI-LMT	120 g	C. Q'ty	Free			Prox. & Exch.		OFF		
Item No.	0	Name																	
Lo-LMT	110 g	HI-LMT	120 g																
C. Q'ty	Free																		
Prox. & Exch.		OFF																	
③	[Set contents selection] Press △ 4 times to select Exchange. When ▽ is pressed, the set contents shift in the reverse direction.	<table border="1"> <tr> <td>Item No.</td> <td>0</td> <td>Name</td> <td></td> </tr> <tr> <td>Lo-LMT</td> <td>110 g</td> <td>HI-LMT</td> <td>120 g</td> </tr> <tr> <td>C. Q'ty</td> <td>Free</td> <td></td> <td></td> </tr> <tr> <td colspan="2">Prox. & Exch.</td> <td colspan="2">Exchange</td> </tr> </table>	Item No.	0	Name		Lo-LMT	110 g	HI-LMT	120 g	C. Q'ty	Free			Prox. & Exch.		Exchange		
Item No.	0	Name																	
Lo-LMT	110 g	HI-LMT	120 g																
C. Q'ty	Free																		
Prox. & Exch.		Exchange																	
④	Press E . The proximity combination is enabled.	<table border="1"> <tr> <td>Item No.</td> <td>0</td> <td>Name</td> <td></td> </tr> <tr> <td>Lo-LMT</td> <td>110 g</td> <td>HI-LMT</td> <td>120 g</td> </tr> <tr> <td>C. Q'ty</td> <td>Free</td> <td>Exch</td> <td></td> </tr> <tr> <td>Unit-L</td> <td>0 g</td> <td>Unit-H</td> <td>0 g</td> </tr> </table>	Item No.	0	Name		Lo-LMT	110 g	HI-LMT	120 g	C. Q'ty	Free	Exch		Unit-L	0 g	Unit-H	0 g	The setting is reflected in the Function/Condition field.
Item No.	0	Name																	
Lo-LMT	110 g	HI-LMT	120 g																
C. Q'ty	Free	Exch																	
Unit-L	0 g	Unit-H	0 g																

Note)

The exchange instruction function does not work unless items to be weighed are put on all weighing units.

28. Remain detecting function

The remain detecting function attempts to preferentially put into a combination the weighing units which have not participated in any combination for a certain period of time since the items to be weighed were put on them. If any of those weighing units have not still participated in any combination for another certain period of time, the lamps corresponding to the weighing unit light in green to indicate that they are remaining.

When the weighed items are removed from those weighing units, the lamps go out.

The certain period of time mentioned above should be set with the user-defined parameter. (From 1 to 60 minutes at one minute intervals)

Setting change should be performed with No. 007 of "User parameters table" in Page (54). For the method of setting user-defined parameters, refer to "How to set user parameters" in Page (52).

The item on a weighing unit, which has not participated in combination for a preset period of time after the elapse of half the preset time (after the elapse of 15 minutes if the preset time is 30 minutes), is judged as remains. This function performs combination calculation so that such a weighing unit is preferentially allowed to participate in combination. During this period, a combination is formed if it falls within the setting range, even though it is not the optimum combination.

If any weighing unit has not participated in combination even after the elapse of a preset time, the function indicates that the weighing unit is remaining by lighting the LED lamp in green. Because the weighing unit that is remaining does not participate in combination, remove the item from the weighing unit. When the item is removed, the green LED goes out.

If the compulsory combination of remains has been selected in advance, the function compulsorily makes weighing units participate in combination when the preset time is exceeded. In such a case, even if any combined weight value is outside the setting range, the function performs combination and the green lamp lights up.





[Functional options]

OFF..... Does not execute remain detection. [Default setting]

Remain Detect..... Remove the remain. (Blinking in green)

Compulsory Combination..... Make a combination with remaining items combination compulsorily (Items are discharged).

<<Example>> When setting the remain detection

	Operating procedure	Displayed contents	Remarks																
①	Press  . The combination function setting mode is established, and "Remain Setting" is displayed.	<table border="1"> <tr> <td>Item No.</td> <td>0</td> <td>Name</td> <td></td> </tr> <tr> <td>Lo-LMT</td> <td>110 g</td> <td>HI-LMT</td> <td>120 g</td> </tr> <tr> <td>C. Q'ty</td> <td>Free</td> <td></td> <td></td> </tr> <tr> <td colspan="2">Remain Setting</td> <td colspan="2">OFF</td> </tr> </table>	Item No.	0	Name		Lo-LMT	110 g	HI-LMT	120 g	C. Q'ty	Free			Remain Setting		OFF		
Item No.	0	Name																	
Lo-LMT	110 g	HI-LMT	120 g																
C. Q'ty	Free																		
Remain Setting		OFF																	
②	[Set contents selection] Press  once to select Remain Detect. When  is pressed, the set contents shift in the reverse direction.	<table border="1"> <tr> <td>Item No.</td> <td>0</td> <td>Name</td> <td></td> </tr> <tr> <td>Lo-LMT</td> <td>110 g</td> <td>HI-LMT</td> <td>120 g</td> </tr> <tr> <td>C. Q'ty</td> <td>Free</td> <td></td> <td></td> </tr> <tr> <td colspan="2">Remain Setting</td> <td colspan="2">Remain Detect</td> </tr> </table>	Item No.	0	Name		Lo-LMT	110 g	HI-LMT	120 g	C. Q'ty	Free			Remain Setting		Remain Detect		
Item No.	0	Name																	
Lo-LMT	110 g	HI-LMT	120 g																
C. Q'ty	Free																		
Remain Setting		Remain Detect																	
③	Press  . The remain detecting function is enabled.	<table border="1"> <tr> <td>Item No.</td> <td>0</td> <td>Name</td> <td></td> </tr> <tr> <td>Lo-LMT</td> <td>110 g</td> <td>HI-LMT</td> <td>120 g</td> </tr> <tr> <td>C. Q'ty</td> <td>Free</td> <td>Remn</td> <td>0 g</td> </tr> <tr> <td>Unit-L</td> <td>0 g</td> <td>Unit-H</td> <td>0 g</td> </tr> </table>	Item No.	0	Name		Lo-LMT	110 g	HI-LMT	120 g	C. Q'ty	Free	Remn	0 g	Unit-L	0 g	Unit-H	0 g	The setting is reflected in the function & condition field.
Item No.	0	Name																	
Lo-LMT	110 g	HI-LMT	120 g																
C. Q'ty	Free	Remn	0 g																
Unit-L	0 g	Unit-H	0 g																









29. Target value setting function

This function sets the goal of production and the target value of combination speed. It can be utilized in production control.

(1) Production goal setting

The production goal can be set in the range of 0 to 6000. When “0” is set, the message “The goal has been achieved” is not shown because it is judged as production goal has not set.

<<Example>> When setting production goal to 100

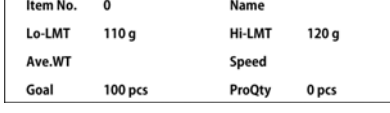
	Operating procedure	Displayed contents	Remarks
①	[Quantity setting] Press  , and then press  .		The set value blinks.
②	Input  ,  and  in this order.		The set value blinks.
③	Press  . The goal has been set up.		Choose “8: Production goal” in User parameter # 36-53, LCD Layout to display “Production goal”.

(2) Operation when the production goal has been reached

When the goal has been reached (for example, when the items involved in the 100th combination have been removed), the buzzer sounds and the message is displayed on the sub-display, as shown in the figure below.

When  is pressed, the buzzer stops and the combination mode is called back.







The goal has been achieved.

[Note]

If the production goal has been reached, the combination operation stops, thus disabling weighing. Change the item or set again the production goal to a value larger than the current goal.

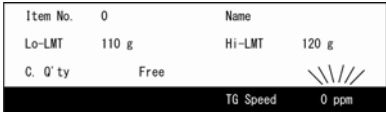
(3) Target Speed setting

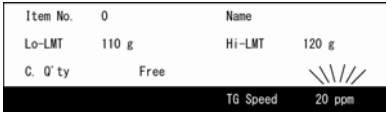

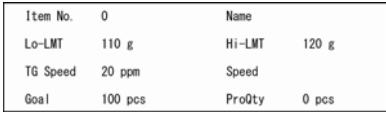



<<Example>> When setting the TG Speed to 20 pcs/min.

	Operating procedure	Displayed contents	Remarks
①	<p>[Quantity setting]</p> <p>Press , and then press .</p>		The set value blinks.
②	<p>Input  and  in this order.</p>		The set value blinks.
③	<p>Press .</p> <p>TG Speed has been set up.</p>		Choose “6: Target speed” in User parameter # 36-53, LCD Layout to display “Target speed”.

30. Suspended scale function

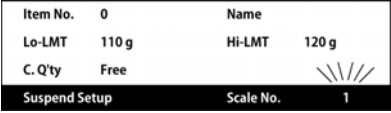
If any weighing unit breaks down, it is possible to suspend the operation of the faulty weighing unit and continue the operation of the remaining weighing units. When the weighing unit is set to "Suspended", the LED lamp lights up.

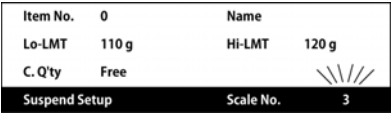
<<Example>> When setting Scale No. 3 as Suspended

	Operating procedure	Displayed contents	Remarks
①	[Suspended scale setting] Press  , and then press  .		The Scale No. blinks.
②	Press  The Scale No. changes to 3.		The scale No. blinks.
③	Press  The Scale No. 3 changes to Suspend.		In case of the 4th screen, "stop" is displayed in Scale No. 3.

[Note]



The same operation applies in the case where the suspension of a scale is cancelled. Perform the above operation when the scale is suspended and "Suspended" is cancelled. It is also possible to set the suspended scale on the Scale Check screen. For the setting method, refer to "Scale check function" in Page (44).

31. Scale check function

This function checks the weight of each weighing unit and changes the settings of the weighing unit.

(1) Check function

This function is capable of checking the respective weight values of 12 weighing units. It stops the combination operation during scale check.

Press , and then press .

The display changes as shown in the figure below.

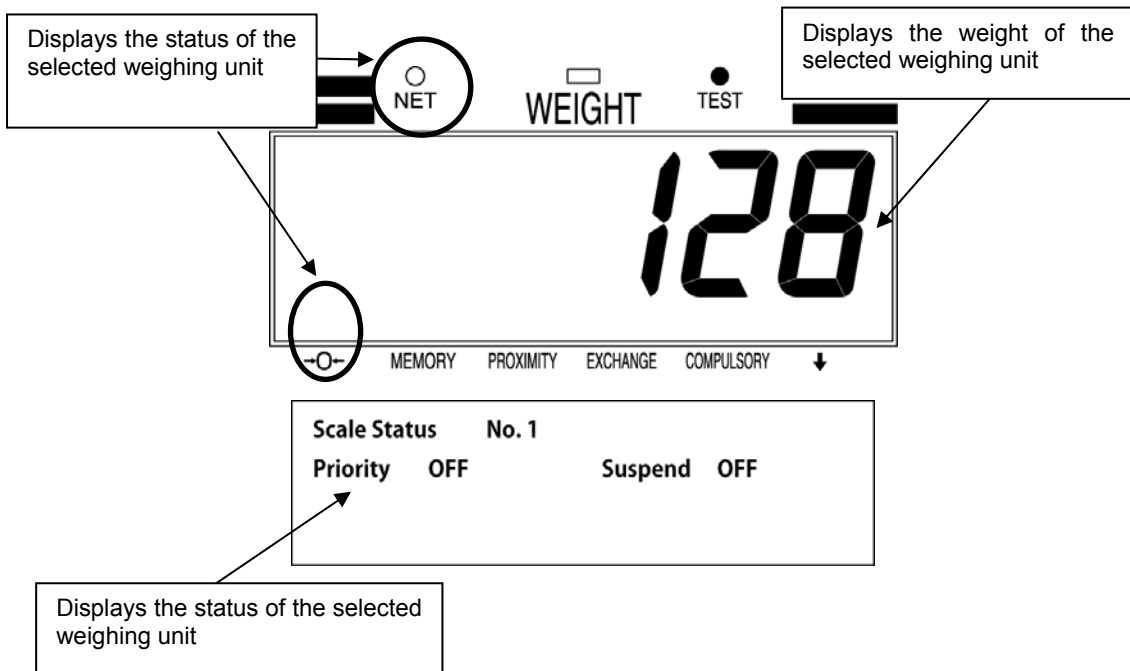



Pressing  enables the tare subtraction of this weighing unit.





Pressing  enables the zero reset of this weighing unit.

Pressing  closes the check screen of this weighing unit.

(2) Checking the weight of other weighing unit

Scale No. 1 is selected at the time of calling-up of the scale check function, but you can switch the weighing unit to display, by pressing  | .

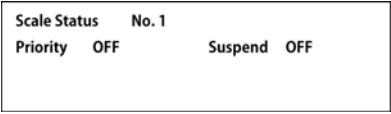

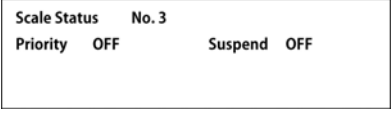

<<Example>> When displaying Scale No. 3

	Operating procedure	Displayed contents	Remarks
①	Press  , and then press  .		
②	[Scale No. selection] Press  twice to display No. 3. When  is pressed, the scale No. shifts in the reverse direction.		

(3) Setting of the prior scale

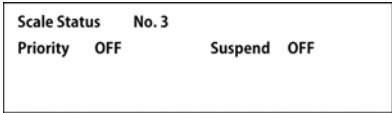
You can change the "Prior scale" setting of a selected weighing unit.

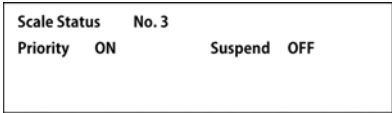



<<Example>> When selecting Scale No. 3 as Priority

	Operating procedure	Displayed contents	Remarks
①	On the Scale Check screen, select Scale No. 3.		
②	[Prior scale setting] Press  , and then press  "Priority" turns ON.		When this operation is performed with "Priority" being ON, "Priority" changes to OFF and the priority on the scale is cancelled.
③	Press  Scale No. 3 changes to Prior.		

(4) Setting of the suspended scale

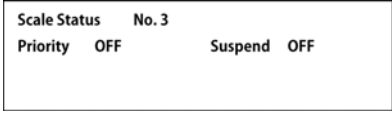

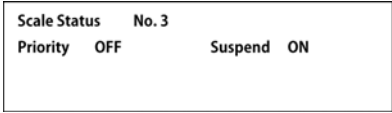
You can change the "Suspended scale" setting of a selected weighing unit.

<<Example>> When setting Scale No. 3 to Suspended

	Operating procedure	Displayed contents	Remarks
①	On the Scale Check screen, select Scale No. 3.		
②	[Suspended scale setting] Press  , and then press  "Suspend" turns ON.		When this operation is performed with "Suspend" being ON, "Suspend" changes to OFF and suspension of the scale is cancelled.
③	Press  Scale No. 3 changes to Suspend.		

32. Other function setting

How to set the area where the scale is used and the stable speed at operation:

	Operating procedure		Remarks
①	While holding down PLU , press T Refer to page 56 “ How to set user parameters”		
②	Press MENU *Press this key twice when memory card is equipped. Other settings are displayed.	 <div style="border: 1px solid black; padding: 5px; width: fit-content;"> <p>Other Settings</p> <p>Gravity Compensation [1] key</p> <p>Stable Speed Setting [2] key</p> </div>	

[Note]

When going back to normal operation mode, press **E** twice.

Stable speed setting

It is possible to set the scale's degree of stability. You can select the degree from following settings.

[Functional options]











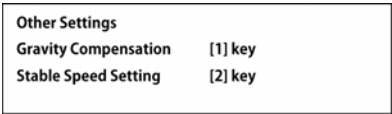

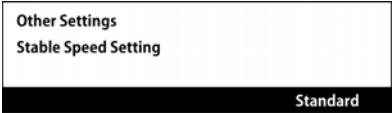
Standard setting: Balanced setting between combination speed and accuracy [Default setting]

Stability against vibration: Set when the vibration in the work environment is large and the Standard setting takes a long time to stabilize the scale state.

It is also recommended when accuracy in combination for careful and stable detection is required.

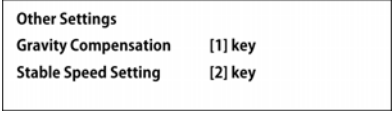

Setting for compatibility with TDW-2100WP: Setting to use the weighing section of TDW-2100WP series

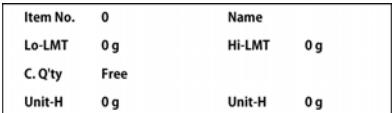
<<Example>> When changing the stable speed to "Stable against vibration"

	Operating procedure	Displayed contents	Remarks
①	Allow Other Settings to be displayed.		
②	[Stable Speed Setting] Press  .		The current Stable Speed Setting is displayed.
③	Press  once to display "Stable against vibration". When  is pressed, the options shift in the reverse direction.		When you do not want to change the setting, press  . Go to ④ without changing the setting.
④	Press  . After the setting is written in a weighing unit, the Other Settings screen returns.		
⑤	Press  . The user-defined parameter setting mode is called back.		
⑥	When  is pressed again, the combination mode is called back.		

33. How to set the date and time

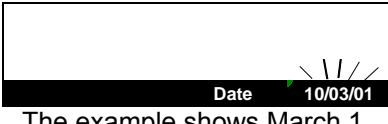
This section describes how to set the date and time of the indicator. Be sure to make this setting when storing the record of combination results by using a memory card option. The indicator has an internal clock, and once it is set, the time and date are automatically incremented.

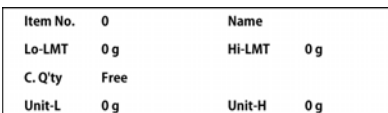
	Operating procedure	Displayed contents	Remarks
①	While pressing PLU , press T . The display shifts to "User defined parameter setting" (Ref. to P56)		
②	Press MENU twice. *When using a memory card, press the key 3 times. Date setting display comes up on screen.	 The example shows March 1, 2010.	The date is shown, from the left, in order of year, month and day each in 2 digits. Year should be entered in the Christian year system.
③	[Date setting] Input year, month and date with numeric key. Press MENU to save the setting date. The display shifts to the time setting.	 (The tenth digit of the hour blinks.)	.Input the year, month and day, in 2 digits each. <<Example>> "March 1, 2010" is entered as "10", "03" and "01".
④	[Time setting] Input the hour and minute in this order with numeric keys.	 The example shows 08:20am.	Time is displayed in 24-hour format. From the left, hour and minute are arranged in this order. To set the time, use the 24-hour format
⑤	Press E twice. The input date and time are stored and combination mode is called back.		Input the hour and minute, each in 2 digits. <<Example>>"8:20 a.m." is displayed as "08" and "20".

[Note]

If the machine is left unused for a long period of time (not plugged into the mains for about one year), the self-charging backup battery becomes empty and the date and time data is erased.

34. How to adjust the display brightness and contrast

1. Press **PLU** while pressing **T**.
"35. How to set user parameters" in Page 51 is displayed.
2. Press **MENU** 4 times. (When using the memory card option, press it five times.)

The sub-display switches as shown below.

FLD	FLD	FLD
Bright: 2	Contr.: 125	Bright: 7
↑ [4] key	↑ [5] key	↑ [6] key
↓ [1] key	↓ [2] key	↓ [3] key

4^{MNO}
DATE: Used to increase the brightness of the main display.

1^{WXYZ}
SCALE: Used to decrease the brightness of the main display.

5^{PQRS}
☺: Used to increase the contrast of the sub-display.

2
⌘: Used to increase the contrast of the sub-display.





6^{TUV}
NAME: Used to increase the brightness of the sub-display.

3
PRIOR: Used to decrease the brightness of the sub-display.

3. Press **E**. The user-defined parameter setting mode is called back.
4. When **E** is pressed again, the combination mode is called back.

35. How to confirm the indicator software version

This section describes how to confirm the indicator software version. Confirm it when you are asked about the version of the indicator by the distributor from which you procured the equipment.

	Operating procedure	Displayed contents	Remarks
①	Press T while pressing PLU . "52. How to set user parameters" in Page 53 is displayed.		
②	Press MENU 5 times. * When using the memory card option, press it 6 times. The software version is displayed.		In this case, the version is V1.00.
③	Press E . The user-defined parameter setting mode is called back.		
④	When E is pressed again, the combination mode is called back.		



36. How to set user parameters

User parameters are available in TSDW and you can change their settings so that it can optimally operate according to the use environment. When changing the settings, refer to "User parameters table" in Page (54).





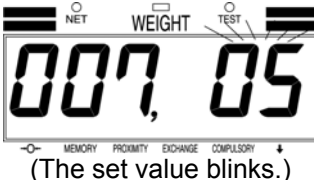
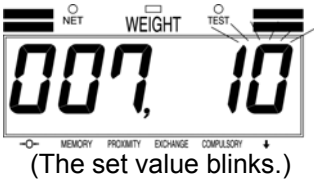

There are two methods to select a parameter number: one method is to display a desired number by using scroll keys, and the other is to display directly with the numeric keys.

This section describes the operation of each method by using an example of changing the parameter number 007 (Remain Detect time) from 5 to 10.

<<Example>> When selecting a number with scrolling keys

	Operating procedure	Displayed contents	Remarks
①	Press T while pressing PLU .	 (The set value blinks.)	The user parameter setting mode is displayed. Three digits on the left side display a parameter number, and three digits on the right side display a set value.
②	Press ▲ to display a parameter number that you want to change. When ▼ is pressed, the numeric value shifts in the reverse direction.	 (The set value blinks.)	Continue to press ▲ and the numeric value is automatically incremented while it is pressed.
③	Change the set value with the numeric keys. Press 1 WXYZ and 0 JKL in this order.	 (The set value blinks.)	When a wrong value is input, clear the input value with C and then input again.
④	When setting other parameters successively, repeat ② and ③ above.	 (The set value blinks.)	
⑤	Press E . The combination mode is called back.	 (The set value blinks.)	At this point, the setting change has been already reflected.

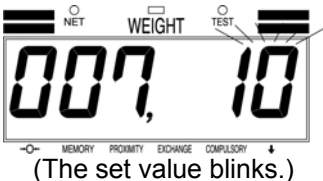
<<Example>> When selecting a number with numeric keys

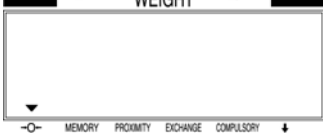
	Operating procedure	Displayed contents	Remarks
①	Press T while pressing PLU .	 (The set value blinks.)	The user parameter setting mode is displayed. Three digits on the left side display a parameter number, and three digits on the right side display a set value.
②	Press T . The parameter number blinks and the parameter number input mode is established.	 (The parameter number blinks.)	
③	Change the parameter number with the numeric keys. Press 7 (ABC/GOAL).	 (The parameter number blinks.)	When a wrong value is input, clear the input value with C and then input again.
④	Press T . The set value input mode for parameter number 007 is established.	 (The set value blinks.)	
⑤	Change the set value with the numeric keys. Press 1 (WXYZ/SCALE) and 0 (JKL) in this order.	 (The set value blinks.)	When a wrong value is input, clear the input value with C and then input again.
⑥	When setting other parameters successively, repeat ② to ⑤ above.	 (The set value blinks.)	
⑦	Press E . The combination mode is called back.		At this point, the setting change has been already reflected.

37. User parameters table







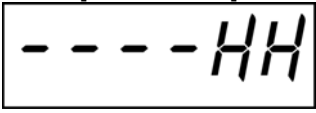

No.	Name	Default	Function
001	Display brightness	2	0: Darkest, 1: Dark, 2: Normal, 3: Bright, 4: Brightest
002	Auto-tuning brightness timer	10	00: No function 01 to 60: The display brightness is changed to 00 after the display state has been stable for the set period of time (minutes).
003	LCD contrast	125	0: Lowest - 255: Highest
004	Combination buzzer	1	Buzzer indicating that the right combination has been found 0: OFF 1: ON
005	Pickup Error Buzzer	1	Buzzer that sounds when the pickup error occurs 0: OFF 1: ON
006	Unit weight upper/lower limit error buzzer	1	Buzzer that sounds when the unit weight upper/lower limit error occurs 0: OFF 1: ON
007	Remain detection time	5	Remain detection time [min.] 0: 5 min. 1 to 60: Set value [min.]
008	Re-zero each time when the weighing items are changed	0	Specify whether to carry out zero-reset at the time of item change 0: No 1: Yes
009	Number of the weighing heads on which the items should be replaced	1	0: Default setting[1] 1-10: The number of items to be replaced at one time In case of use of the exchange instruction function, and when no combination is formed
010	LED indication of loading position	1	* This is a parameter for the TDW-305. Do not set it to other than the standard value.
011	Display screen after setting	1	Select the screen to be displayed after the completion of making a setting in the Normal mode. 0: The system always returns to the 1st screen after the completion of setting. 1: The screen just before the setting operation is displayed after the completion of setting.
012	Channel 1 Communication mode	0	0: Disables communication function 1: Connects to external scale (Bluetooth) 2: Connects to external scale (RS-232C)
019	Channel 2 Communication mode	2	0: Disables communication function 1: Connects to external scale 2: Connects to PLC
021	Channel2 Parity	1	0: Non Parity 1: Even Parity
026	Channel 3 Communication mode	0	0: Disables communication function 1: Enables memory card communication (Weighing result not output) 2: Enables memory card communication (Weighing result to be output)
033	Communication error display	0	0: Does not display communication error 1: Displays communication error
034	Automatic Power-on	0	0: The display does not turn on when the power is plugged in. 1: The display turns on when the power is plugged in.
035	Recall Item No. 1 at power-on	0	0: Nothing is called up. 1: Item No. 1 is automatically called up.

No.	Name	Default	Function	
036	LCD layout (1st display(1)/ 2nd line/ left)	09	00: Not displayed 01: Quantity combination set value 02: Usage state of the remain, proximity, exchange and priority functions 03: Unit-L value 04: Unit-H value 05: Average weight 06: Target speed 07: Current speed 08: Production goal 09: Actual production 10: Remain detection time 11: Date(yy/mm/dd) 12: Time 13: Lower limit 14: Upper limit 15: Item No., Item name (2 lines used) 16: Remaining production 17: Weight of weighing loss 18: Remaining time 19: Production quantity graph 20: Average weight transition graph 21: Speed graph	
037	LCD layout (1st display(2)/ 2nd line/ right)	16		
038	LCD layout (1st display(3)/ 3rd line/ left)	05		
039	LCD layout (1st display(4)/ 3rd line/ right)	17		
040	LCD layout (1st display(5)/ 4th line/ left)	07		
041	LCD layout (1st display(6)/ 4th line/ right)	18		
042	LCD layout (2nd display(1)/ 2nd line/ left)	09		
043	LCD layout (2nd display(2)/ 2nd line/ right)	19		
044	LCD layout (2nd display(3)/ 3rd line/ left)	05		
045	LCD layout (2nd display(4)/ 3rd line/ right)	20		
046	LCD layout (2nd display(5)/ 4th line/ left)	07		
047	LCD layout (2nd display(6)/ 4th line/ right)	21		
048	LCD layout (3rd display(1)/ 2nd line/ left)	13		
049	LCD layout (3rd display(2)/ 2nd line/ right)	14		
050	LCD layout (3rd display(3)/ 3rd line/ left)	01		
051	LCD layout (3rd display(4)/ 3rd line/ right)	02		
052	LCD layout (3rd display(5)/ 4th line/ left)	03		
053	LCD layout (3rd display(6)/ 4th line/ right)	04		
054	Display screen at power on	00		0: 1st display 1: 2nd display 2: 3rd display 3: 4th display
055	Motion time of weighing conveyor	10		Set value x 100ms
056	Travel distance of collating conveyor	20		20: Standard More than 20: Travels longer than standard by ((Set value)-20) x 100ms. Less than 20: Travels shorter than standard by ((Set value)-20) x 100ms.
057	Interlock setting with following conveyor	1	0: Interlocking with following conveyor Be sure to connect signal line to the following conveyor. Power on of the following conveyor. 1: No interlock setting (stand-alone operation) Connect signal line for following conveyor to associated short-circuiting connector.	
058	Waiting time until next combination for process of following conveyor	0	Waiting time until next combination for process in following conveyor device. (x100ms) *When connecting to the following conveyor and to take some time to process, starting time of next combination can be delayed for specified ms.	
059	Zero point error	0	TSDW can detect the zero point error when products are placed too quickly before the zero point detection or when all products are not discharged properly. 0: The error lamp lights and TSDW shuts down until the error is released. (The products should be once removed from the head) 1: The error lamp lights but other heads continue to make a combination. (The lamp goes out when the products are once removed) 2: The error lamp does not light and all the heads continue to make a combination. Setting at 1 or 2 is not recommended as defective packages due to discharge failure or weighing error may be produced.	



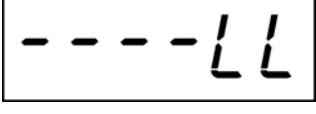

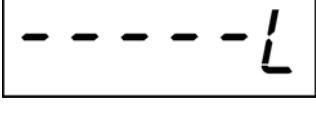

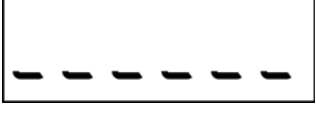



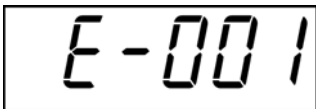
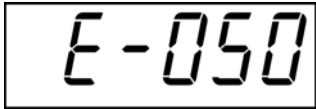

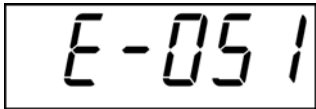

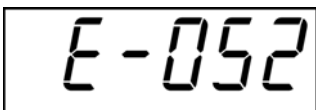

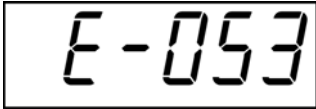
Item No.	1	Item	Sample
	(1)		(2)
	(3)		(4)
	(5)		(6)

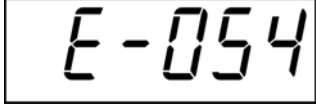

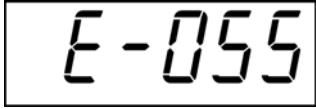

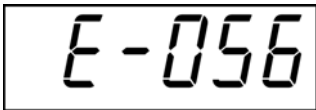
38. Error display

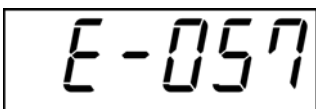
(1) Error of the weighing unit

Displayed contents	Displayed in such instances	Countermeasure to be taken
<p>[Scale check]</p>  <p>[4th screen] ---HH</p>	<p>This may be displayed when the power is turned on while an item is left on the table of a weighing unit.</p>	<p>Remove the item on the table, and then press .</p>
<p>[Scale check]</p>  <p>[4th screen] ----H</p>	<p>This may be displayed when an item is left on the table of the weighing unit and  is pressed to make a zero reset.</p>	<p>"0 g" is displayed and the weighing unit becomes enabled.</p>
<p>[Scale check]</p>  <p>[4th screen] ---LL</p>	<p>This may be displayed when the power is turned on with foreign objects caught between the table and the case of the weighing unit or with the table removed.</p>	<p>Install the table correctly, and then press .</p>
<p>[Scale check]</p>  <p>[4th screen] ----L</p>	<p>This may be displayed when the table of the weighing unit is removed, and  is pressed to make a zero reset.</p>	<p>"0 g" is displayed and the weighing unit becomes enabled.</p>
<p>[Scale check]</p>  <p>[4th screen] -OF-</p>	<p>This is displayed when an item beyond the weighing capacity of the scale is placed on it during use.</p>	<p>When the item is removed, the screen returns to the weight display. Place items within the capacity range of the scale.</p>
<p>[Scale check]</p>  <p>[4th screen] -UF-</p>	<p>This is displayed when the table of the scale is removed during use.</p>	<p>Install the table correctly. "0 g" is displayed and the weighing unit becomes enabled.</p>

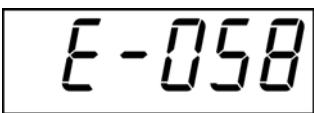
(2) Error of the indicator

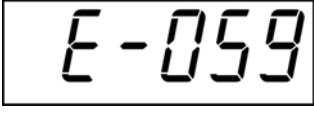
Displayed contents	Displayed in such instances	Countermeasure to be taken
	This is displayed when the indicator has trouble in communicating with the weighing unit.	After turning power off, check the connections of the power cable and the communication cable between the indicator and the weighing units. Then turn power on again.
	< In case of the memory card used> This is displayed when the memory card is not inserted properly.	Press  for releasing from the error and confirm that the memory card is inserted properly.
	< In case of the memory card used> This is displayed when the improper memory card is inserted.	Press  for releasing from the error and change the memory card..
	< In case of the memory card used> This is displayed when the memory card formatted with improper filing system is inserted.	Press  for releasing from the error and install it onto a PC for reformatting to FAT form.
	< In case of the memory card used> This is displayed when trying to write on the protected memory card.	Press  for releasing from the error and install it onto a PC for releasing the lock for the protection switch of the memory card.
	< In case of the memory card used> This is displayed when the memory card does not have enough room to write.	Press  for releasing from the error and install it onto a PC for deleting some unnecessary data and securing room.
	< In case of the memory card used> This is displayed when the memory card has some trouble.	Press  for releasing from the error and exchange to a normal memory card.
	< In case of the memory card used> This is displayed when the capacity of the file to write down reaches to 2GB.	Press  for releasing from the error and install it onto a PC for relocating the file from the memory card.
	< In case of the memory card used> This is displayed when the file to write down is not found.	Press  for releasing from the error an reformat the memory card with the indicator.

Displayed contents	Displayed in such instances	Countermeasure to be taken
	<In case of the memory card used> This is displayed when trying to write on the file read only.	Press  for releasing from the error and install it onto a PC for changing the attribute of the file so that it can be written.
	<In case of the memory card used> This is displayed when the folder to access is not found.	Press  for releasing from the error an reformat the memory card with the indicator.

Remarks:

Such error messages as shown above will not appear when the scale is operated properly.

If any error message as shown above should appear, please take the necessary procedures according to "countermeasure to be taken".

If the error should not be solved or if you have an error message "E-101" and up, please contact the dealer you bought the scale from.

39. Specifications

1. Model : TSDW-205 W (IP65) / TSDW-205 (IP42)
2. Weighing System : Strain Gauge Load Cell
3. Weighing Capacity : 1,500 g
4. Display Division : 1 g (Combination Accuracy 0.1 g)
5. Tare Max. : 1,500 g (Up to the weighing capacity)
6. Range of Combination : 8 g to 6,000 g
7. Combination Speed : 20 to 25 packs/minute (Depending on weighing products & conditions)
8. Number of scale : 12 Heads
9. Outer Dimensions : 1553(L) x 735(W) x 1005 to 1085(H) mm
10. Conveyor Size : Weighing conveyor 214(L) x 120(W) mm
Collating conveyor 1327(L) x 160(W) mm (Flat type)
11. Net Weight : Approx. 150kg (TSDW-205W) / 130kg (TSDW-205)
12. Main Display : Fluorescent Tube (7 segments x 6 digits)
Display, 32(H) x 14.6(W) mm
13. Auxiliary Display : Full-dot LCD Display,
Dot size: 0.50 (H) x 0.50 (W) mm
14. Operating section : 24 keys
15. No. of stored items : Max. 100 items
16. Functions : Zero reset, One-touch tare, Keyboard tare,
Weight check of each head

Priority combination, Exchange instruction, Weight & Quantity combination, Over/under detect, Production goal, Re-calculation, Remain detection function, Proximity combination function

Speed adjustment of weighing conveyor (5 steps)
Speed adjustment of collating conveyor (5 steps)
Switchable simultaneous dump or grouping dump.

17. Operating Temperature : 0 to 40 degrees C
18. Humidity : 30% to 85%RH (No condensation)
19. Power : AC100V, 110V, 120V, 200V, 220V, 230V (+10%~ -15%), 50/60Hz
20. Power Consumption : Approx. 570W (Flat collating conveyor)
Approx. 620W (V belt collating conveyor)

21. Outside Dimension

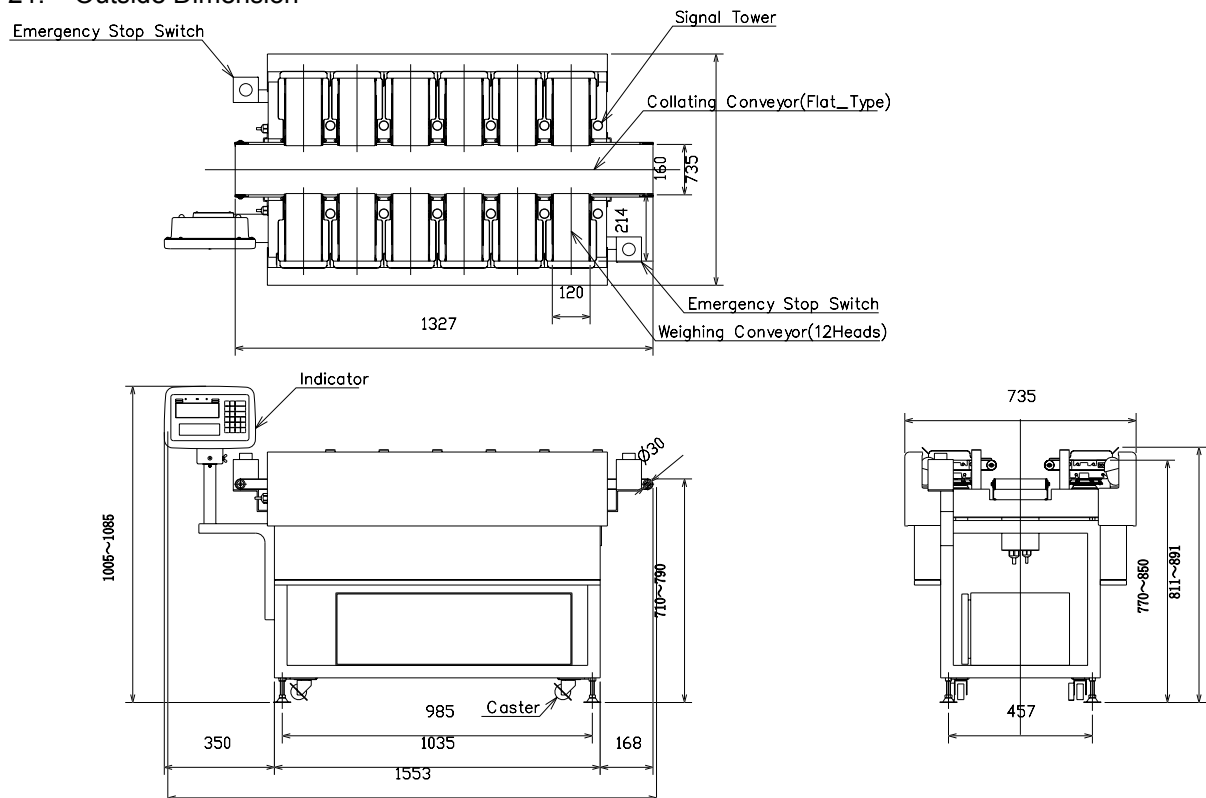

YAMATO SCALE CO., LTD..

5-22 Saenba-cho, Akashi 673-8688, Japan

Telephone: +81-78-918-6157

Fax : +81-78-918-5562

PRINTED IN JAPAN